

TPS92638-Q1 8-Channel Linear LED Driver With PWM Dimming

1 Features

- Qualified for Automotive Applications
 - Device Temperature Grade 1: -40°C to 125°C Ambient Operating Temperature Range
 - Device HBM ESD Classification Level H2
 - Device CDM ESD Classification Level C3B
- [Functional safety capable](#)
 - Documentation available to aid functional safety system design
- 8-Channel LED Driver With Analog and PWM Dimming
- Wide Input-Voltage Range: 5 V–40 V
- Adjustable Constant Output Current Set by Reference Resistor
 - Maximum Current: 70 mA per Channel
 - Maximum Current: 560 mA in Parallel Operation Mode
 - Accuracy: $\pm 3\%$ per Channel
 - Accuracy: $\pm 4\%$ per Device
- PWM Dimming Input (PWM)
 - Turn ON/OFF Delay Time: 25 μs (typ.), 45 μs (max.)
- 4-Bank PWM Dimming to Control 8 Channels
- Open- and Shorted-LED Detection With Deglitch
- Fault Pin for Open, Short, and Thermal-Shutdown Failure Reporting, Allowing Parallel Bus Connection of up to 15 Devices
- Temperature-Current Foldback to Prevent Thermal Shutdown, With Programmable Threshold
- Single Resistor for Stop-Current Set Point
- Single Resistor for Tail-Current Set Point
- Operating Junction Temperature Range -40°C to 150°C
- Package: 20-Pin Thermally Enhanced PWP Package (PDSO)

2 Applications

LED Lighting Applications (for example, daytime running light, position light, fog light, rear light, stop or tail light, interior lighting)

3 Description

The TPS92638-Q1 is an eight-channel linear LED driver with PWM dimming control. Its design is ideal for driving multiple strings of LEDs up to a medium power range.

This device can drive up to eight strings with one to three LEDs in each string, at a total current up to 70 mA per channel. Outputs can be in parallel to provide higher-current drive up to 560 mA.

In multiple-string applications, the device offers the advantage of having common-cathode connection of the LED strings. So, there is only a single return wire needed instead of one per LED string that a system with low-side current sense would need.

The device has the capability for switching LED current between high current and low current for stop and tail applications. Two reference resistors set the two LED current levels from each output.

The included temperature monitor reduces the LED drive current if the IC junction temperature exceeds a thermal threshold. The temperature threshold is programmable through an external resistor. One can disable the thermal current-monitor feature by connecting the TEMP pin to ground. Output of the junction temperature as an analog voltage is available as a factory program option.

Device Information(1)

PART NUMBER	PACKAGE	BODY SIZE (NOM)
TPS92638-Q1	HTSSOP (20)	6.50 mm x 4.40 mm

(1) For all available packages, see the orderable addendum at the end of the datasheet.

4 Typical Application Schematic

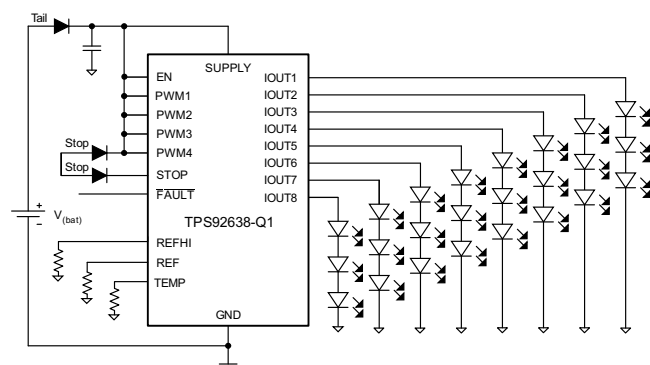

Table of Contents

1 Features	1	9.2 Functional Block Diagram	13
2 Applications	1	9.3 Feature Description	14
3 Description	1	9.4 Device Functional Modes	20
4 Typical Application Schematic	1	10 Application and Implementation	21
5 Revision History	2	10.1 Application Information	21
6 Pin Configuration and Functions	3	10.2 Typical Applications	21
7 Specifications	4	11 Power Supply Recommendations	28
7.1 Absolute Maximum Ratings	4	12 Layout	28
7.2 ESD Ratings	4	12.1 Layout Guidelines	28
7.3 Recommended Operating Conditions	4	12.2 Layout Example	28
7.4 Thermal Information	4	12.3 Thermal Information	29
7.5 Electrical Characteristics	5	13 Device and Documentation Support	30
7.6 Switching Characteristics	6	13.1 Trademarks	30
7.7 Typical Characteristics	7	13.2 Electrostatic Discharge Caution	30
8 Parameter Measurement Information	12	13.3 Glossary	30
9 Detailed Description	13	14 Mechanical, Packaging, and Orderable Information	30
9.1 Overview	13		

5 Revision History

Changes from Revision B (March 2015) to Revision C Page

- Added functional safety link to the [Features](#) section **1**

Changes from Revision A (November 2014) to Revision B Page

- Changed values for channel accuracy and device accuracy **1**
- Deleted text from the fourth paragraph of the Description section **1**

Changes from Original (September 2014) to Revision A Page

- Changed some items on the Features list **1**
- Changed the items in the Applications section **1**
- Changed the paragraphs of the Description section with new text **1**
- Deleted the existing Pin Functions table and replaced with new one **3**
- Added new sections and subsections to the data sheet beginning with the Specifications section **4**

6 Pin Configuration and Functions

**20-Pin PDSO With PowerPAD Package
PWP Package
(Top View)**

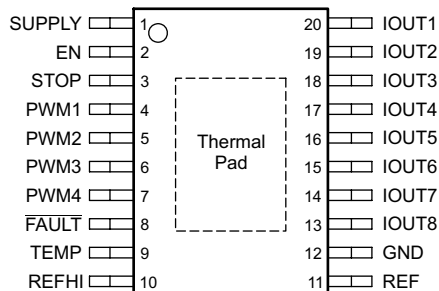

Pin Functions

PIN		I/O	DESCRIPTION
NAME	NO.		
EN	2	I	Enable and shutdown
FAULT	8	I/O	Fault pin
GND	12	—	Ground
IOUT1	20	O	Current output pin
IOUT2	19	O	Current output pin
IOUT3	18	O	Current output pin
IOUT4	17	O	Current output pin
IOUT5	16	O	Current output pin
IOUT6	15	O	Current output pin
IOUT7	14	O	Current output pin
IOUT8	13	O	Current output pin
PWM1	4	I	PWM input and channel ON-OFF for CH1 and CH2
PWM2	5	I	PWM input and channel ON-OFF for CH3 and CH4
PWM3	6	I	PWM input and channel ON-OFF for CH5 and CH6
PWM4	7	I	PWM input and channel ON-OFF for CH7 and CH8
REF	11	I	Reference resistor terminal for normal current setting
REFHI	10	I	Reference resistor pin for stop light current setting
STOP	3	I	Signal input for the stop light
SUPPLY	1	I	Input pin – VBAT supply
TEMP	9	I	Temperature foldback threshold programming

7 Specifications

7.1 Absolute Maximum Ratings

 over operating free-air temperature range (unless otherwise noted)⁽¹⁾

		MIN	MAX	UNIT
SUPPLY, IOUTx, PWMx, EN, STOP	Unregulated input ⁽²⁾ ⁽³⁾	-0.3	45	V
$\overline{\text{FAULT}}$	See ⁽²⁾	-0.3	22	V
REF, REFHI, TEMP	See ⁽²⁾	-0.3	7	V
T _J	Virtual junction temperature range	-40	150	°C
T _A	Operating ambient temperature range	-40	125	°C
T _{stg}	Storage temperature range	-65	150	°C

- (1) Stresses beyond those listed under *Absolute Maximum Ratings* may cause permanent damage to the device. These are stress ratings only, which do not imply functional operation of the device at these or any other conditions beyond those indicated under *Recommended Operating Conditions*. Exposure to absolute-maximum-rated conditions for extended periods may affect device reliability.
- (2) All voltage values are with respect to GND.
- (3) Absolute maximum voltage 45 V for 200 ms

7.2 ESD Ratings

			VALUE	UNIT	
V _(ESD)	Electrostatic discharge	Human body model (HBM), per AEC Q100-002 ⁽¹⁾	±2000	V	
		Charged device model (CDM), per AEC Q100-011	Corner pins (SUPPLY, IOUT1, REF and REFHI)		±750
			Other pins		±500

- (1) AEC Q100-002 indicates that HBM stressing shall be in accordance with the ANSI/ESDA/JEDEC JS-001 specification.

7.3 Recommended Operating Conditions

over operating free-air temperature range (unless otherwise noted)

		MIN	NOM	MAX	UNIT
SUPPLY		5		40	V
V _{IH}	EN, STOP	2		40	V
	$\overline{\text{FAULT}}$	2		20	
	PWMx	2		40	
V _{IL}	EN, STOP	0		0.7	V
	$\overline{\text{FAULT}}$	0		0.7	
	PWMx	0		0.7	
REF, REFHI, TEMP		0		5	V
T _J	Operating junction temperature range	-40		150	°C

7.4 Thermal Information

THERMAL METRIC ⁽¹⁾		TPS92638-Q1	UNIT
		PWP (HTSSOP)	
		20 PINS	
R _{θJA}	Junction-to-ambient thermal resistance	37.8	°C/W
R _{θJC(top)}	Junction-to-case (top) thermal resistance	25.2	°C/W
R _{θJB}	Junction-to-board thermal resistance	21.7	°C/W
ψ _{JT}	Junction-to-top characterization parameter	0.8	°C/W
ψ _{JB}	Junction-to-board characterization parameter	21.5	°C/W
R _{θJC(bot)}	Junction-to-case (bottom) thermal resistance	2.1	°C/W

- (1) For more information about traditional and new thermal metrics, see the *Semiconductor and IC Package Thermal Metrics* application report, [SPRA953](#).

7.5 Electrical Characteristics

 $V_{(VIN)} = 14\text{ V}$, $T_J = -40^\circ\text{C}$ to 150°C (unless otherwise stated)

PARAMETER		TEST CONDITIONS	MIN	TYP	MAX	UNIT
SUPPLY VOLTAGE AND CURRENT (SUPPLY)						
$I_{(Quiescent)}$	Quiescent current	$V_{(PWMx)}$, $V_{(EN)} = \text{high}$, $I_{(IOUTx)} = 40\text{ mA}$	0.5	0.6	0.9	mA
$I_{(Shutdown)}$	Shutdown current	$V_{(PWMx)} = 0\text{ V}$, $V_{(EN)} = 0\text{ V}$			10	μA
$I_{(fault)}$	Shutdown current in fault mode (device to GND)	$V_{(PWMx)}$, $V_{(EN)} = \text{high}$, $V_{(FAULT)} = \text{low}$, $V_{(SUPPLY)} = 5\text{ V to } 40\text{ V}$, $I_{(IOUTx)} = 30\text{ mA}$	0.5	0.75	1	mA
	Shutdown current in fault mode (from SUPPLY)				1.15	
PWM, EN, STOP						
$I_{(EN-pd)}$	EN internal pulldown	$V_{(EN)} = 0\text{ V to } 40\text{ V}$	0.5		5	μA
$V_{IH(PWMx)}$	Logic input, high level ⁽¹⁾	PWMx rising from a low state, IOUTx disabled	1.161	1.222	1.283	V
$V_{IL(PWMx)}$	Logic input, low level ⁽¹⁾	PWMx falling from a high state, IOUTx enabled	1.119	1.178	1.237	V
$V_{(PWM-hys)}$	Hysteresis			44		mV
$I_{(PWM-pd)}$	PWMx internal pulldown current	$V_{(PWMx)} = 0\text{ V to } 20\text{ V}$		180	300	nA
		$V_{(PWMx)} = 20\text{ V to } 40\text{ V}$		0.2	2	μA
$I_{(STOP-PD)}$	STOP internal pulldown	$V_{(STOP)} = 0\text{ V to } 40\text{ V}$	0.1		1	μA
CURRENT REGULATION (IOUTx)						
$I_{(IOUTx)}$	Regulated output current range	Each channel, $V_{(PWMx)} = \text{high}$, $V_{(EN)} = \text{high}$ $V_{(SUPPLY)} > 5\text{ V}$, $V_{(IOUTx)} > 0.9\text{ V}$	2		70	mA
$I_{(IOUT_TOTAL)}$		8 channels in parallel mode, $V_{(PWMx)} = \text{high}$, $V_{(EN)} = \text{high}$, $V_{(SUPPLY)} > 5\text{ V}$, $V_{(IOUTx)} > 0.9\text{ V}$	16		560	mA
$\Delta I_{O(\text{channel})}$	Channel accuracy	$5\text{ mA} \leq I_{(IOUTx)} < 10\text{ mA}$, $V_{(SUPPLY)} = 5\text{ V} - 40\text{ V}$ Channel accuracy = $(I_{(IOUTx)} - I_{(avg)}) / I_{(avg)}$ ⁽²⁾	-7%		7%	
		$10\text{ mA} \leq I_{(IOUTx)} \leq 70\text{ mA}$, $V_{(SUPPLY)} = 5\text{ V} - 40\text{ V}$ Channel accuracy = $(I_{(IOUTx)} - I_{(avg)}) / I_{(avg)}$ ⁽²⁾	-3%		3%	
		$2\text{ mA} \leq I_{(IOUTx)} < 5\text{ mA}$, $V_{(SUPPLY)} = 5\text{ V} - 40\text{ V}$ Channel accuracy = $(I_{(IOUTx)} - I_{(avg)}) / I_{(avg)}$ ⁽²⁾	-18%		18%	
$\Delta I_{O(\text{device})}$	Device accuracy	$5\text{ mA} \leq I_{(IOUTx)} < 10\text{ mA}$, $V_{(SUPPLY)} = 5\text{ V to } 20\text{ V}$ Device accuracy = $(I_{(IOUTx)} - I_{(setting)}) / I_{(setting)}$ ⁽³⁾	-8%		8%	
		$10\text{ mA} \leq I_{(IOUTx)} \leq 70\text{ mA}$, $V_{(SUPPLY)} = 5\text{ V to } 20\text{ V}$ Device accuracy = $(I_{(IOUTx)} - I_{(setting)}) / I_{(setting)}$ ⁽³⁾	-4%		4%	
		$2\text{ mA} \leq I_{(IOUTx)} < 5\text{ mA}$, $V_{(SUPPLY)} = 5\text{ V to } 20\text{ V}$ Device accuracy = $(I_{(IOUTx)} - I_{(setting)}) / I_{(setting)}$ ⁽³⁾	-20%		20%	
		$5\text{ mA} \leq I_{(IOUTx)} < 10\text{ mA}$, $V_{(SUPPLY)} = 20\text{ V to } 40\text{ V}$ Device accuracy = $(I_{(IOUTx)} - I_{(setting)}) / I_{(setting)}$ ⁽³⁾	-10%		10%	
		$10\text{ mA} \leq I_{(IOUTx)} \leq 70\text{ mA}$, $V_{(SUPPLY)} = 20\text{ V to } 40\text{ V}$ Device accuracy = $(I_{(IOUTx)} - I_{(setting)}) / I_{(setting)}$ ⁽³⁾	-8%		8%	
		$2\text{ mA} \leq I_{(IOUTx)} < 5\text{ mA}$, $V_{(SUPPLY)} = 20\text{ V to } 40\text{ V}$ Device accuracy = $(I_{(IOUTx)} - I_{(setting)}) / I_{(setting)}$ ⁽³⁾	-20%		20%	
$V_{(REF)}$	Reference voltage	$I_{(IOUTx)} = 20\text{ mA}$	1.198	1.222	1.246	V
$V_{(REFHI)}$	STOP reference voltage		1.198	1.222	1.246	V
$G_{(I)}$	Ratio of $I_{(IOUTx)}$ to reference current $I_{(IOUTx)} / I_{(REF)}$ or $I_{(IOUTx)} / (I_{(REF)} + I_{(REFHI)})$			200		mA/mA
$V_{(DROP_IOUTx)}$	Dropout voltage	$I_{(IOUTx)} = 70\text{ mA}$		0.71	0.9	V
$V_{(DROP)}$		$I_{(IOUTx)} = 35\text{ mA}$		0.28	0.45	V

(1) V_{IH} and V_{IL} track each other. That is, both are simultaneously at MAX, MIN, or the same intermediate point. Therefore, there can be no overlap of the V_{IH} and V_{IL} values during normal operation.

(2) $I_{(AVG)} = [I_{(IOUT1)} + I_{(IOUT2)} + I_{(IOUT3)} + I_{(IOUT4)} + I_{(IOUT5)} + I_{(IOUT6)} + I_{(IOUT7)} + I_{(IOUT8)}] / 8$

(3) $I_{(setting)}$ is the target current set by R_(REF).

Electrical Characteristics (continued)

 $V_{(VIN)} = 14\text{ V}$, $T_J = -40^\circ\text{C}$ to 150°C (unless otherwise stated)

PARAMETER	TEST CONDITIONS	MIN	TYP	MAX	UNIT
$I_{(slew)}$ Current slew-rate rise and fall times	Current rising from 10% to 90% or falling from 90% to 10% at $I_{(IOUTx)} = 35\text{ mA}$. ⁽⁴⁾	1.5	6	12	mA/μs
	Current rising from 10% to 90% or falling from 90% to 10% at $I_{(IOUTx)} = 70\text{ mA}$. ⁽⁴⁾	3	6	12	mA/μs
FAULT (FAULT)					
V_{OL} Logic output low level	500-μA external pullup			0.4	V
V_{OH} Logic output high level	1-μA external pulldown	2			V
$I_{(pulldown)}$ Strong pulldown current		600	780	1000	μA
$I_{(pullup)}$ Pullup current		4	8	12	μA
PROTECTION					
$V_{(OL_th)}$ Open-load detection voltage $V_{(OL_TH)} = V_{(SUPPLY)} - V_{(IOUTx)}$		50	100	150	mV
$V_{(OL_hys)}$ Open-load detection hysteresis		100	200	300	mV
$V_{(SHORT_th)}$ Short-detection voltage		0.846	0.89	0.935	V
$V_{(SHORT_hys)}$ Short-detection hysteresis		318	335	352	mV
$N_{(SHORT_deg)}$ Open-load detection PWM deglitch cycle number		7		8	Cycles
$R_{(REF_th)}$, $R_{(REFHI_th)}$ REF and REFHI pins, parallel-resistor short detection		1400		2300	Ω
THERMAL MONITOR					
$T_{(shutdown)}$ Thermal shutdown		155	170		°C
$T_{(hys)}$ Thermal shutdown hysteresis			15		°C
$T_{(th)}$ Thermal foldback activation temperature	$I_{(IOUTx)} = 90\% \times I_{(setting)}$, TEMP terminal floating	95	110	125	°C
$I_{(TFC-min)}$ Minimum foldback current, ratio of $I_{(setting)}$		40%	50%	60%	
$V_{(T-disable)}$ Thermal-foldback-function disable threshold of $V_{(TEMP)}$		0		0.2	V
$K_{(temp1)}$ Change of $V_{(TEMP)}$ relative to $T_{(J)}$			25		mV/°C

(4) See [Parameter Measurement Information](#) for the load model for the slew-rate test and delay-time test.

7.6 Switching Characteristics

PARAMETER	TEST CONDITION	MIN	TYP	MAX	UNIT
$t_{(startup)}$ Start-up time	$V_{(SUPPLY)} > 5\text{ V}$, $I_{(IOUTx)} = 15\text{ mA}$, $I_{(setting)} = 30\text{ mA}$ ⁽¹⁾			150	μs
$t_{d(on)}$ Delay time between PWM rising edge to 10% of $I_{(IOUTx)}$	Two LEDs in series, 10-kΩ resistor in parallel		20	45	μs
$t_{d(off)}$ Delay time between PWM falling edge to 90% of $I_{(IOUTx)}$	Two LEDs in series, 10-kΩ resistor in parallel		20	45	μs
Open-load detection deglitch		1.2	2.2	3.2	ms
	During PWM, count the number of continuous cycles when $V_{(SUPPLY)} - V_{(IOUTx)} < V_{(OL_th)}$	7		8	Cycles
Short-detection deglitch		1.2	2.2	3.2	ms
	During PWM, count the number of continuous cycles when $V_{(IOUTx)} < V_{(SHORT_th)}$	7		8	Cycles

(1) Start-up is complete when $I_{(setting)}$ is 30 mA and $I_{(IOUTx)}$ increases from 0 to 15 mA.

7.7 Typical Characteristics

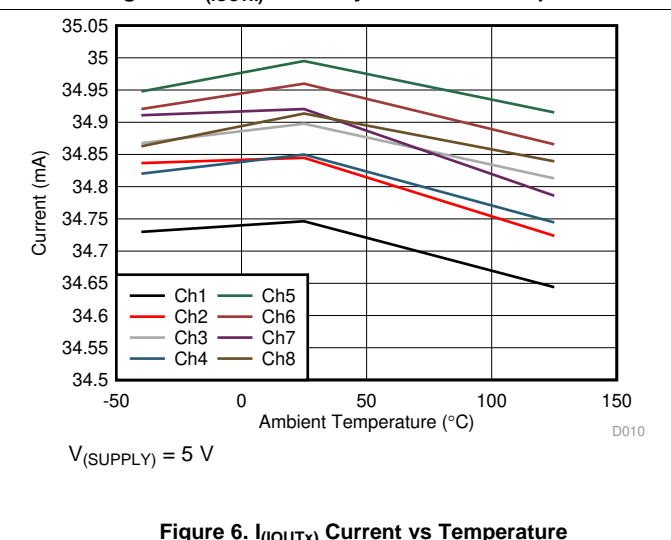
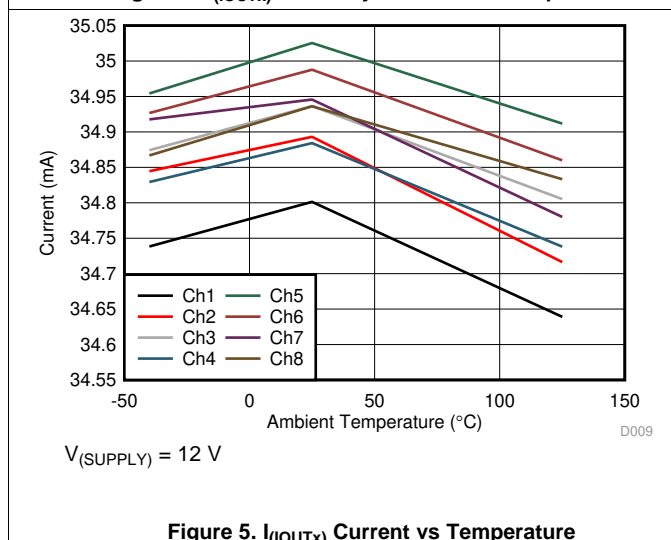
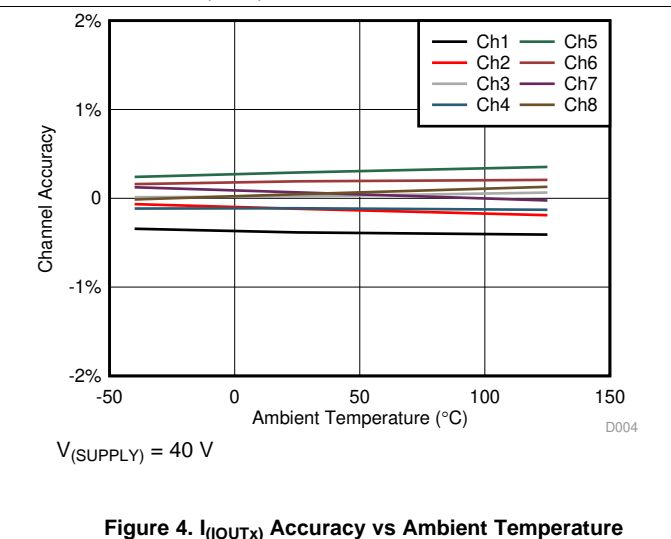
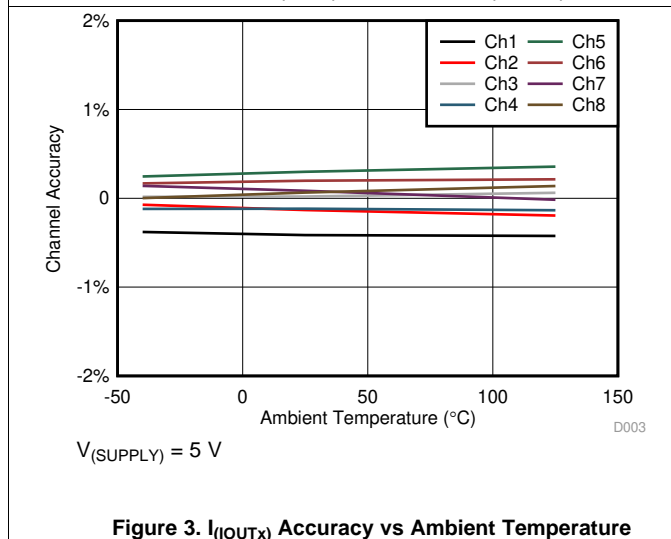
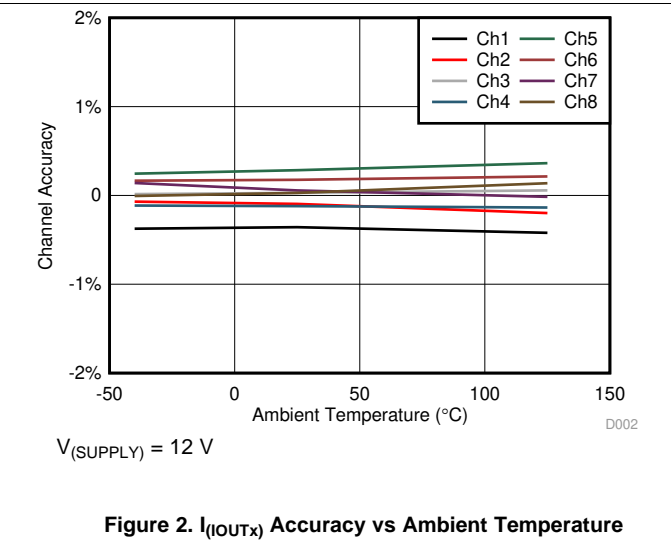
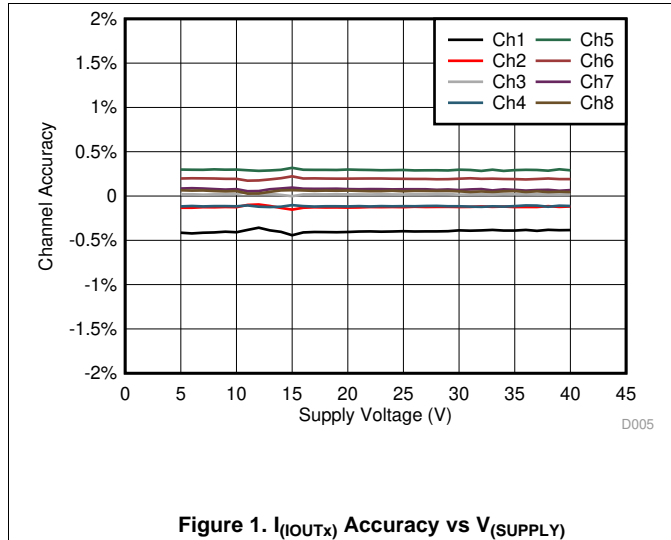

Typical Characteristics (continued)

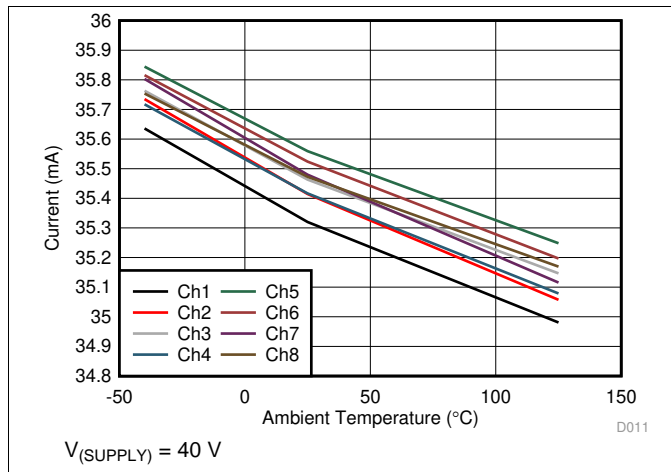

Figure 7. $I_{(IOUTx)}$ Current vs Temperature

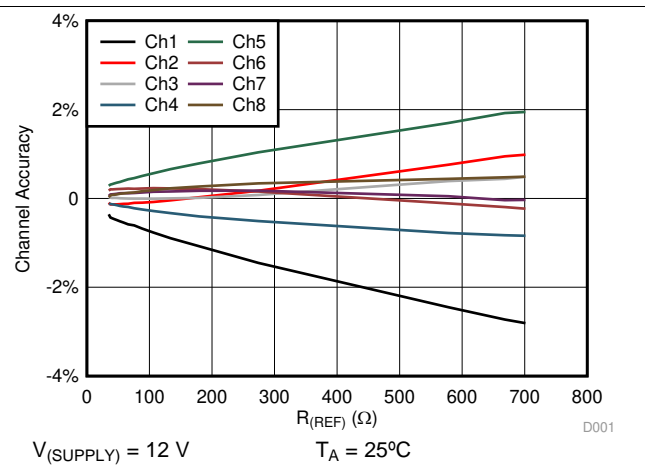

Figure 8. $I_{(IOUTx)}$ Channel Accuracy vs $R_{(REF)}$

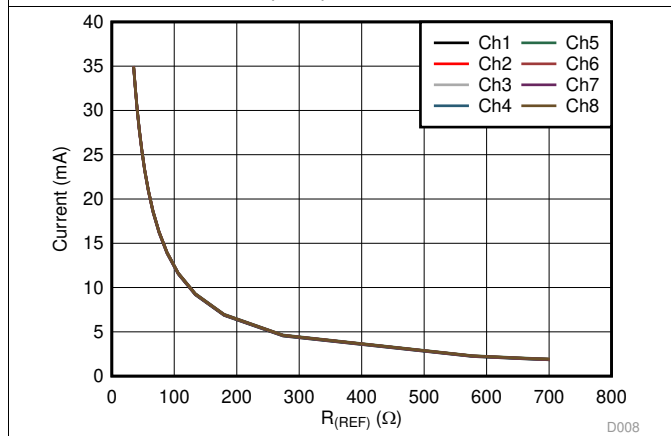

Figure 9. $I_{(IOUTx)}$ Current vs $R_{(REF)}$

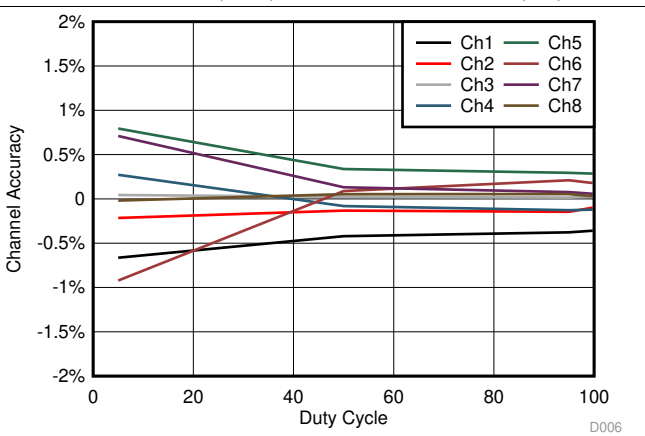

Figure 10. $I_{(IOUTx)}$ Accuracy vs PWM Duty Cycle

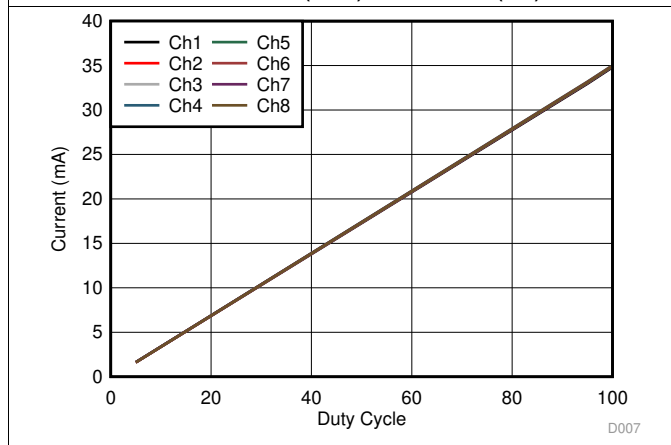

Figure 11. $I_{(IOUTx)}$ Current vs PWM Duty Cycle

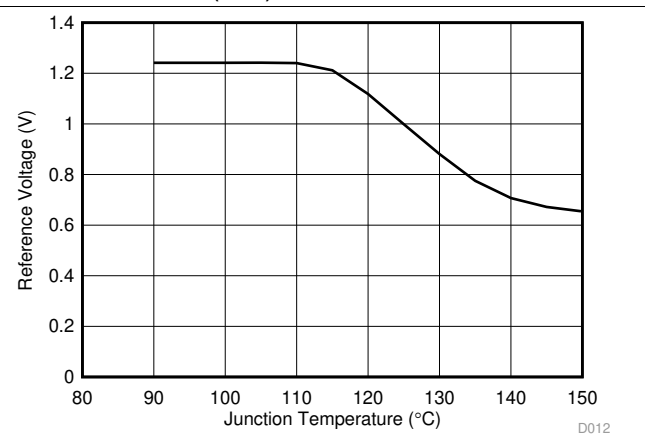

Figure 12. Reference Voltage vs Junction Temperature

Typical Characteristics (continued)

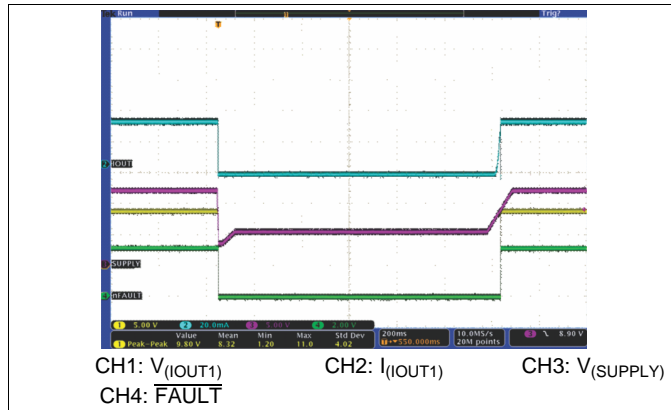

Figure 13. Cold Cranking Behavior

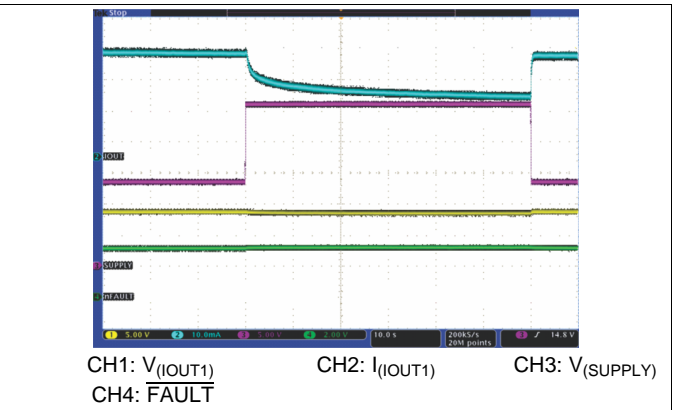

Figure 14. Jump Start From 13.5 V to 26 V

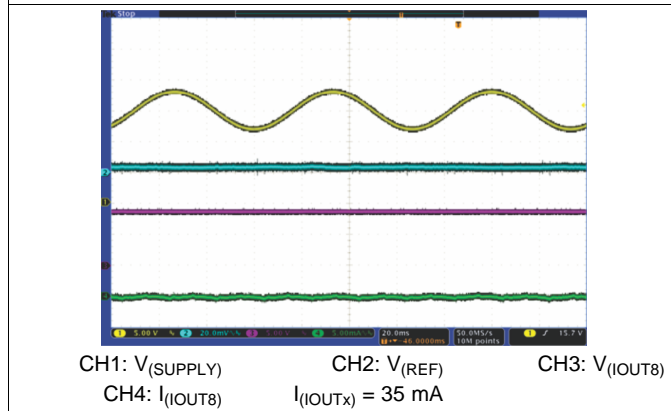

Figure 15. Superimposed Alternating Voltage, 12 V–18 V, 15 Hz

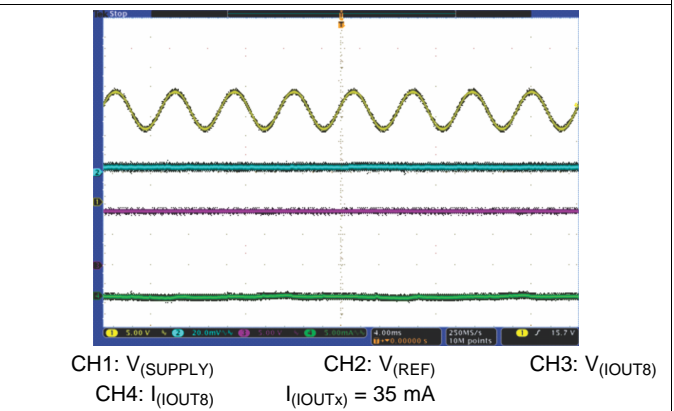

Figure 16. Superimposed Alternating Voltage, 12 V–18 V, 200 Hz

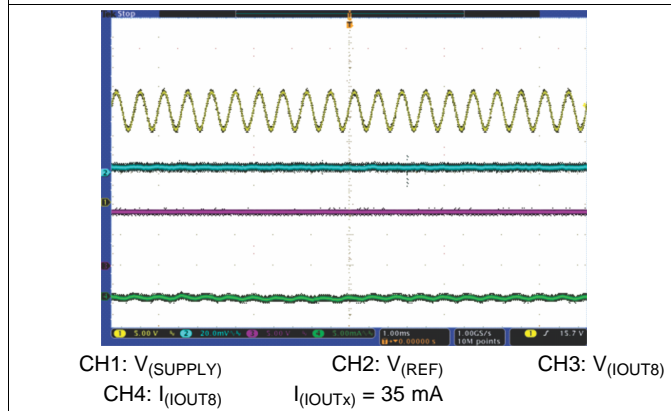

Figure 17. Superimposed Alternating Voltage, 12 V–18 V, 2 kHz

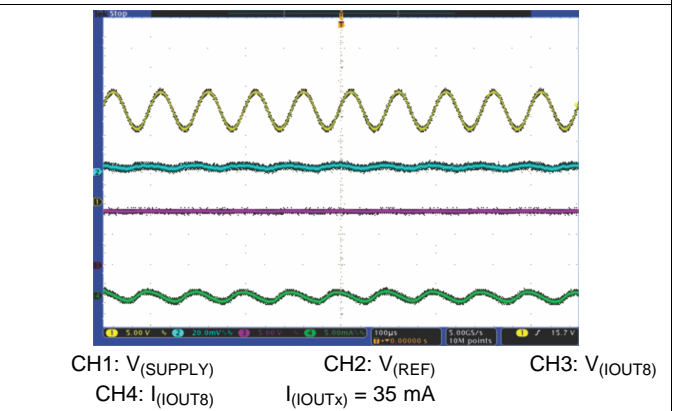

Figure 18. Superimposed Alternating Voltage, 12 V–18 V, 10 kHz

Typical Characteristics (continued)

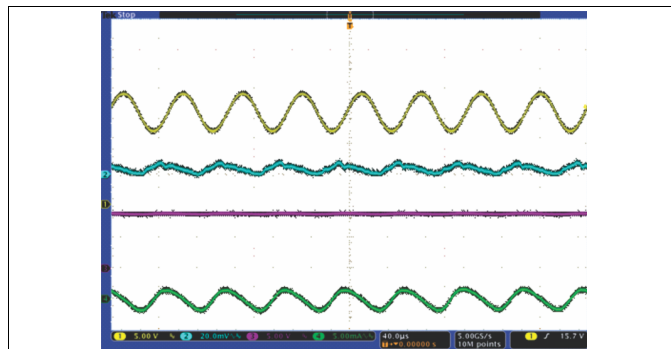

Figure 19. Superimposed Alternating Voltage, 12 V–18 V, 20 kHz

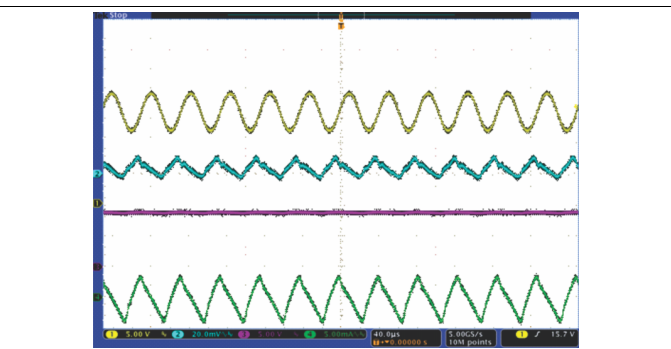

Figure 20. Superimposed Alternating Voltage, 12 V–18 V, 30 kHz

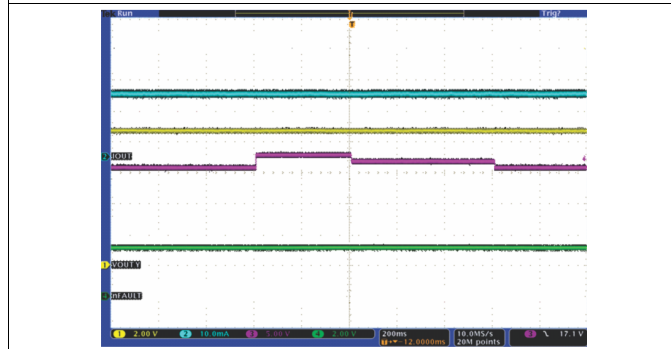

Figure 21. Transient Overvoltage (16 V – 18 V – 17 V – 16 V)

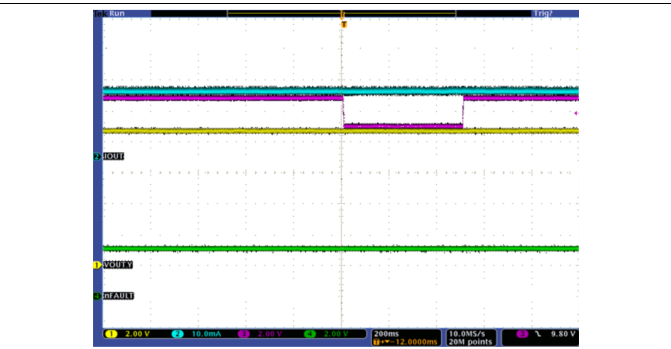

Figure 22. Transient Undervoltage (10.8 V – 9 V – 10.8 V)

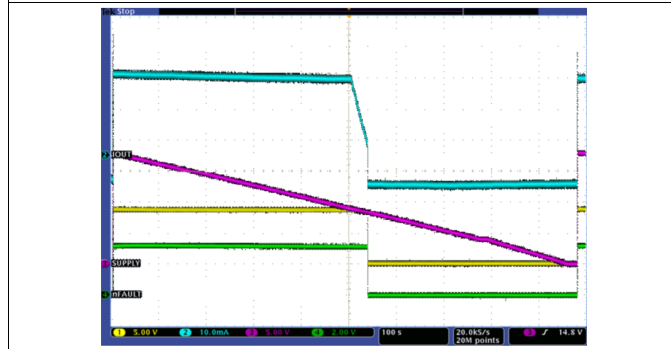

Figure 23. Slow Decrease and Quick Increase

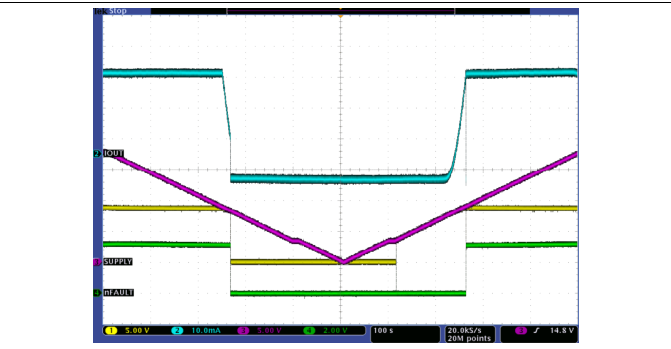
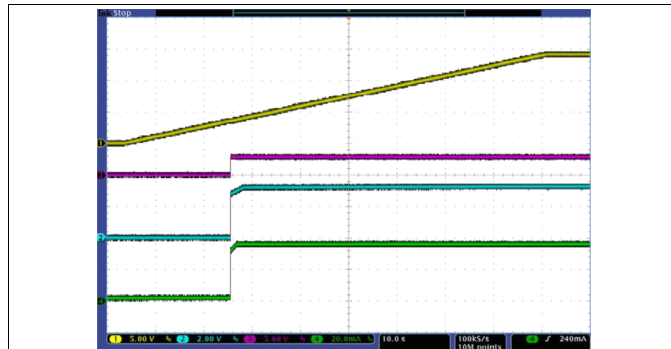

Figure 24. Slow Decrease and Slow Increase

Typical Characteristics (continued)



CH1: $V_{(SUPPLY)}$ CH2: $V_{(FAULT)}$ CH3: $V_{(REF)}$
CH4: $I_{(IOUT8)}$

Figure 25. Slow Power Up ($V_{(SUPPLY)}$, $V_{(EN)}$, $V_{(PWMx)}$ Rise Together From 0 V to 14 V by 0.2 V/s)

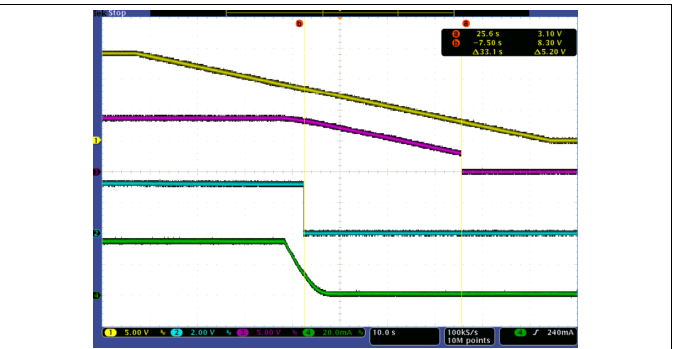

CH1: $V_{(SUPPLY)}$ CH2: $V_{(FAULT)}$ CH3: $V_{(REF)}$
CH4: $I_{(IOUT8)}$

Figure 26. Slow Power Down ($V_{(SUPPLY)}$, $V_{(EN)}$, $V_{(PWMx)}$ Fall Together From 14 V to 0 V by 0.2 V/s)



CH1: $V_{(PWM3)}$ CH2: $V_{(PWM4)}$ CH3: $V_{(REF)}$
CH4: $I_{(IOUT8)}$ Duty cycle = 50% $V_{(SUPPLY)}$, $V_{(EN)}$ = 14 V

Figure 27. PWM Dimming, Dimming Frequency = 1000 Hz

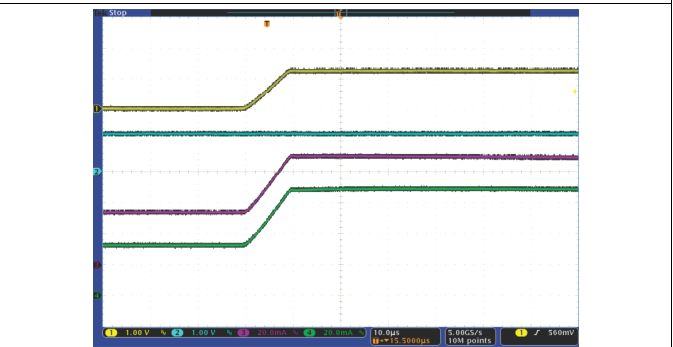

CH1: $V_{(REFHI)}$ CH2: $V_{(REF)}$ CH3: $I_{(IOUT1)}$
CH4: $I_{(IOUT8)}$

Figure 28. Load Transient, $I_{(IOUTx)}$ Increases From 35 mA to 70 mA



CH1: $V_{(REFHI)}$ CH2: $V_{(REF)}$ CH3: $I_{(IOUT1)}$
CH4: $I_{(IOUT8)}$

Figure 29. Load Transient, $I_{(IOUTx)}$ Decreases From 70 mA to 35 mA

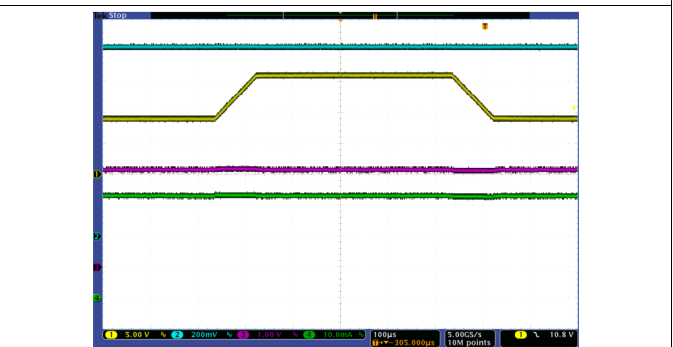

CH1: $V_{(SUPPLY)}$ CH2: $V_{(REF)}$ CH3: $V_{(FAULT)}$
 $I_{(IOUTx)}$ = 35 mA

Figure 30. Line Transient, $V_{(SUPPLY)}$, $V_{(EN)}$, $V_{(PWMx)}$ Ramp From 9 V to 16 V to 9 V by 0.1 V/ μ s

TPS92638-Q1

SLVSCK5C – SEPTEMBER 2014 – REVISED JANUARY 2020

www.ti.com

8 Parameter Measurement Information

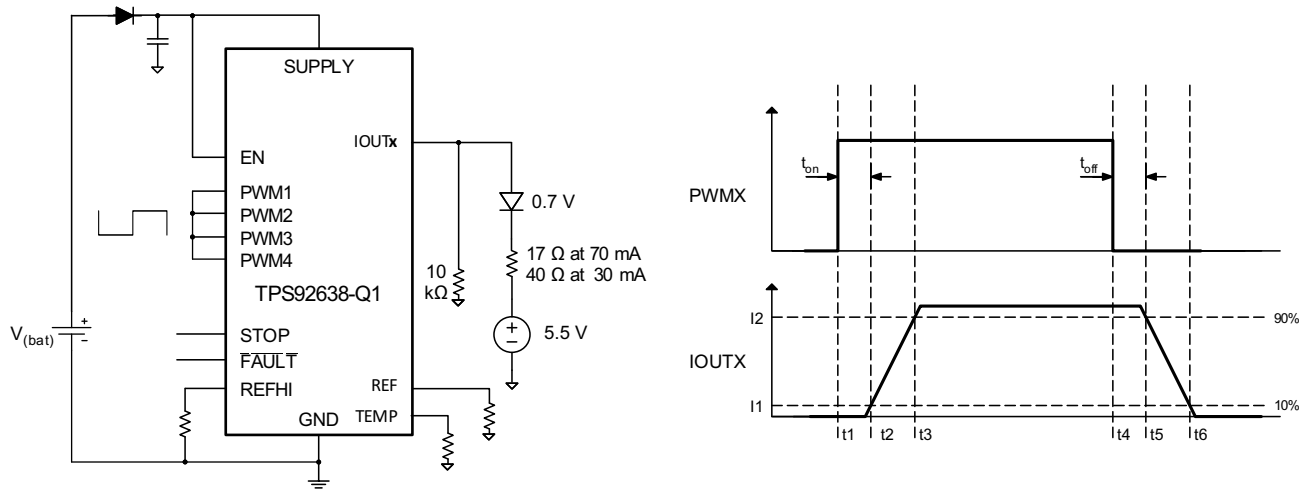

Figure 31. TPS92638-Q1 Test Circuit and Waveforms

9 Detailed Description

9.1 Overview

The TPS92638-Q1 device is an 8-channel constant-current regulator with PWM dimming, designed for high-brightness red or white LEDs in automotive lighting applications. Each channel has up to 70-mA current capability and 560 mA when paralleled. The device provides excellent current matching between channels and devices. The high-side current source allows LED common-cathode connection. The advanced control loop allows high accuracy between channels even with different numbers of LEDs connected on the output.

The design of the TPS92638-Q1 device is specifically for use in STOP-and-TAIL applications where the LED current switches between a high current (indicating stop or brake) and a lower current (for normal taillight operation).

The TPS92638-Q1 device monitors fault conditions on the output and reports its status on the $\overline{\text{FAULT}}$ pin. The device features output short-to-ground detection, open-load detection, and thermal shutdown. The $\overline{\text{FAULT}}$ pin allows maximum flexibility for determining the fault mode and reporting to the MCU in case of an error. For applications lacking an MCU, connecting multiple TPS92638-Q1 devices in a bus is an option.

Integrated thermal foldback protects the device from thermal shutdown by reducing the output current linearly when reaching a preset threshold. Provision for programming the temperature foldback threshold is through an external resistor. Tying the TEMP pin to ground disables this function.

9.2 Functional Block Diagram

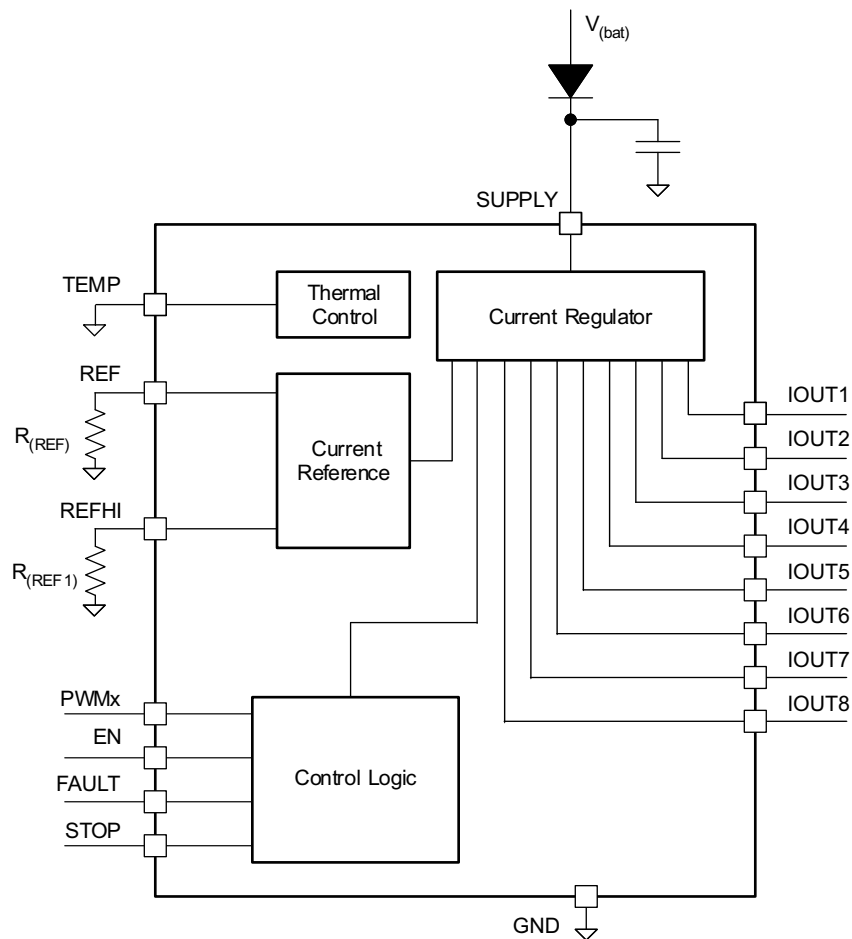

9.3 Feature Description

9.3.1 LED Current Setting

Independent linear current regulators control the eight LED output channels. Global external resistors set the current of each channel. The device also features two current levels, intended for stop and tail applications.

The internal current reference, $I_{(REF)}$, has two possible values depending on the state of the STOP input: When STOP is low, REF, the current drawn from the REF pin, controls the output current. When STOP is high, the sum of the currents drawn from the REFHI pin and REF pin controls the output current.

Equations [Equation 1](#) and [Equation 2](#) calculate values for the current-setting resistors:

when STOP = low

$$I_{(OUTx-TAIL)} = \frac{V_{ref} \times G_{(l)}}{R_{(REF)}}$$

$$R_{(REF)} = \frac{V_{ref} \times G_{(l)}}{I_{(OUTx-TAIL)}} \quad (1)$$

when STOP = high

$$I_{(IOUTx-STOP)} = \frac{V_{ref} \times G_{(l)}}{R_{(REFHI)}} + \frac{V_{ref} \times G_{(l)}}{R_{(REF)}}$$

$$R_{(REFHI)} = \frac{V_{ref} \times G_{(l)}}{I_{(IOUTx-STOP)} - \frac{V_{ref} \times G_{(l)}}{R_{(REF)}}} \quad (2)$$

where

V_{ref} is the internal reference voltage

$G_{(l)}$ is the ratio of output current to reference current

9.3.2 PWM Control

The device features four independent PWM-bank dimming-control pins, each of which controls one bank consisting of two channels. A PWM input can also function as a shutdown pin for an unused bank. Tying PWM to ground disables the corresponding outputs. The PWM signal has a precise threshold, which a designer can use to define the start-up voltage of an LED as an undervoltage-lockout (UVLO) function with a divider resistor from SUPPLY. [Table 1](#) shows the PWM bank mapping.

Table 1. PWM Bank Mapping

PWM INPUT	CONTROLLED OUTPUTS
PWM1	OUT1, OUT2
PWM2	OUT3, OUT4
PWM3	OUT5, OUT6
PWM4	OUT7, OUT8

9.3.3 Fault Diagnostics

The TPS92638-Q1 device has a fault pin, \overline{FAULT} , which is for the short, open, and thermal-shutdown general faults. This arrangement allows the maximum flexibility based on all requirements and application conditions.

Connection the device \overline{FAULT} pin to the MCU allows for fault reporting. The \overline{FAULT} pin is an open-drain transistor with a weak internal pullup.

The device releases the FAULT bus when external circuitry toggles the FAULT bus, or on a power cycle of the device. In an application that has no MCU, only cycling power clears the fault.

The following faults result in the $\overline{\text{FAULT}}$ pin going low: thermal shutdown, open load, or output short circuit. For thermal shutdown and open LED, release of the $\overline{\text{FAULT}}$ pin occurs when the thermal shutdown or open-LED condition no longer exists. For other faults, the $\overline{\text{FAULT}}$ pin remains low even after the condition does not exist, and clearing is only possible by toggling $\overline{\text{FAULT}}$ or by power cycling of the device.

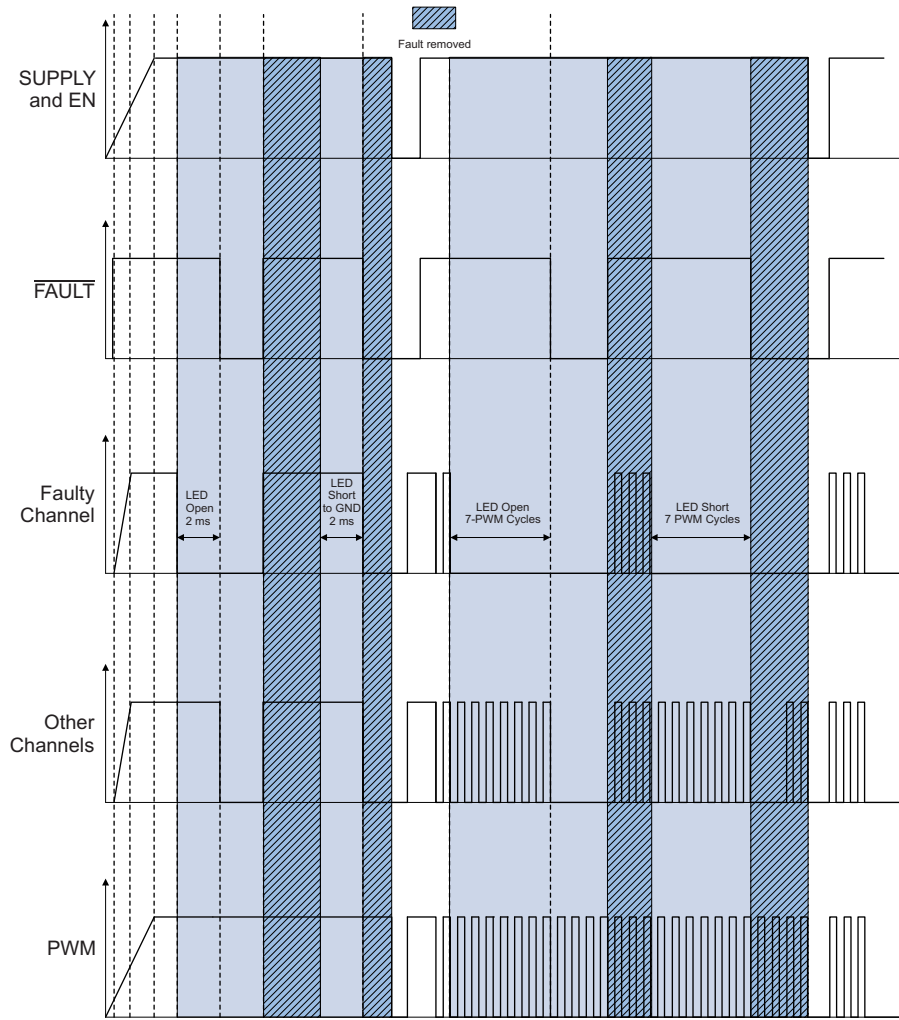

Figure 32. TPS92638-Q1 Device Fault-Handling Behavior, $\overline{\text{FAULT}}$ Bus Floating

The design of an application with no MCU allows the connecting together of up to 15 TPS92638-Q1 $\overline{\text{FAULT}}$ pins. When one or more devices have errors, their corresponding $\overline{\text{FAULT}}$ pins go low, thus pulling down the connected $\overline{\text{FAULT}}$ bus and shutting down all device outputs. [Figure 33](#) illustrates the $\overline{\text{FAULT}}$ line bus connection.

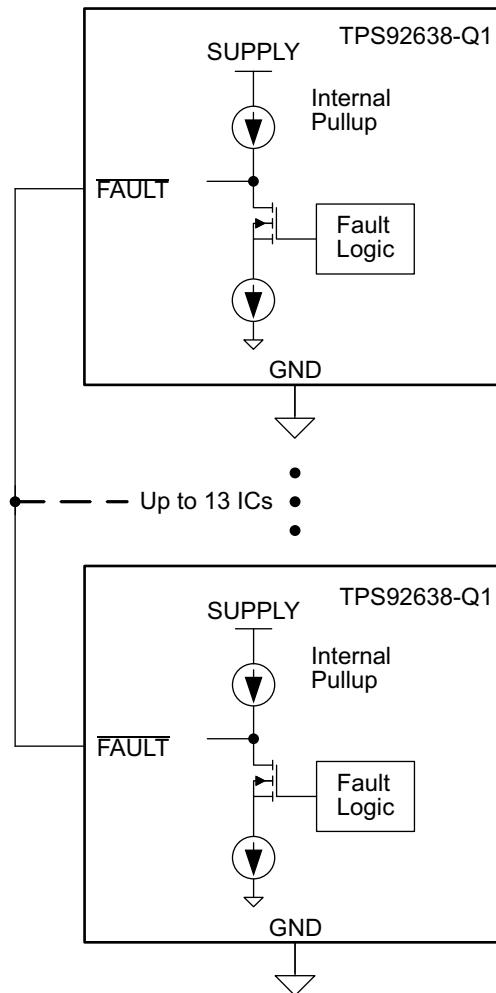

Figure 33. Connection of FAULT Line Bus

The device releases the FAULT bus by external circuitry pulling the FAULT bus high, by toggling of the EN pin, or by a power cycle of the device. In an application without an MCU, only a power cycle clears the fault. [Figure 34](#) is a detailed timing diagram.

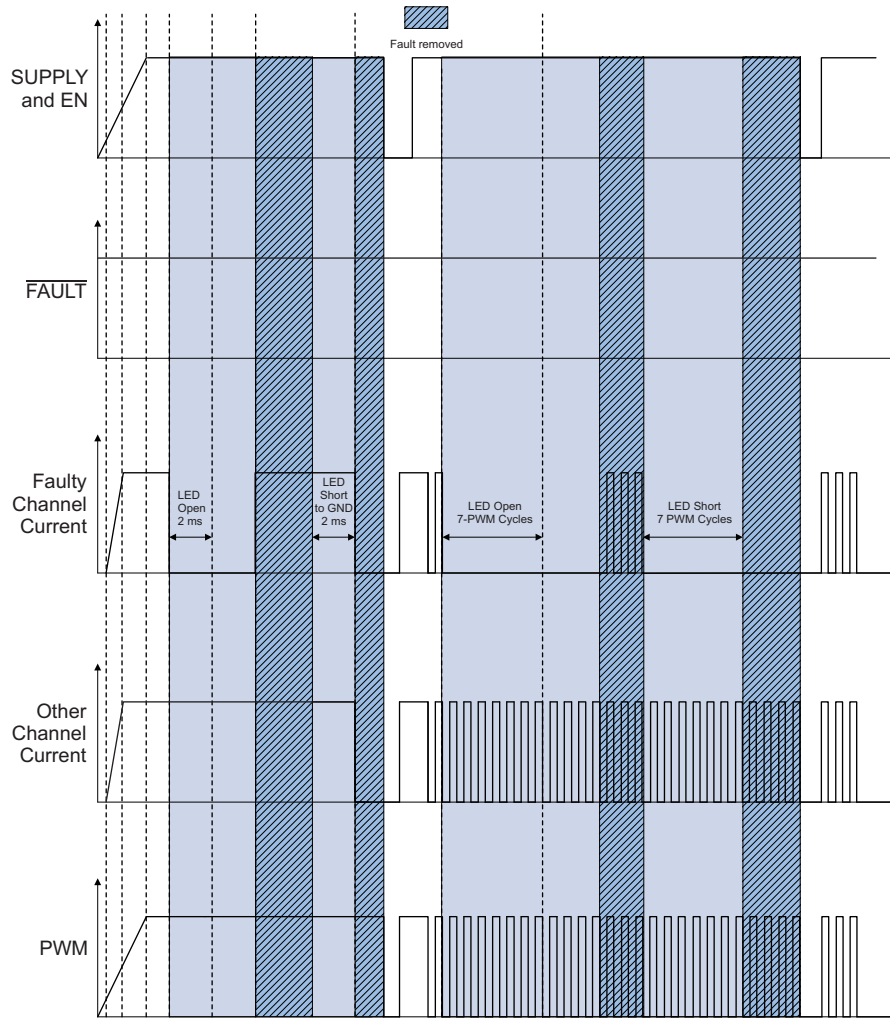

Figure 34. TPS92638-Q1 Device Fault-Handling Behavior, FAULT Bus Externally Pulled High

Table 2. Fault Table

FAILURE MODE	JUDGMENT CONDITION			DIAGNOSTIC OUTPUT PIN ⁽¹⁾	ACTION	FAULT	DEVICE REACTION	FAILURE REMOVED	SELF CLEARING
	DETECTION VOLTAGE	CHANNEL STATUS	DETECTION MECHANISM						
Short Circuit: 1 or several LED strings	$V_{(SUPPLY)} > 5\text{ V}$	On	$V_{(IOUTx)} < 0.9\text{ V}$	$\overline{\text{FAULT}}$	Pulled low	Externally pulled high	Failing strings turned off, other CHs on	Toggle EN, power cycle	No
						Floating	All strings turned OFF	Toggle EN, power cycle	
Open Load: 1 or several LED strings	$V_{(SUPPLY)} > 5\text{ V}$	On	$V_{(SUPPLY)} - V_{(IOUTx)} < 100\text{ mV}$	$\overline{\text{FAULT}}$	Pulled low	Externally pulled high	All strings stay ON	Failure condition removed	Yes
						Floating	Failing strings stay ON, other CHs turned OFF	Failure condition removed	
Short to Battery: 1 or several LED strings	$V_{(SUPPLY)} > 5\text{ V}$	On or off	$V_{(SUPPLY)} - V_{(IOUTx)} < 100\text{ mV}$	$\overline{\text{FAULT}}$	Pulled low	Externally pulled high	All strings stay ON	Failure condition removed	Yes
						Floating	Failing strings stay ON, other CHs turned OFF	Failure condition removed	
Thermal Shutdown	$V_{(SUPPLY)} > 5\text{ V}$	On or off	$> 170^\circ\text{C}$	$\overline{\text{FAULT}}$	Pulled low	Externally pulled high	All strings turned OFF	Temperature $< 155^\circ\text{C}$	Yes
						Floating			
Thermal Foldback	$V_{(SUPPLY)} > 5\text{ V}$	On or off	$> 110^\circ\text{C}$	N/A	None	N/A	Reduced current to all strings	Temperature $< 100^\circ\text{C}$	Yes
Reference Resistor Short	$V_{(SUPPLY)} > 5\text{ V}$	On or off	$R_{(ref)} < 1400\ \Omega$	$\overline{\text{FAULT}}$	Pulled low	N/A	All strings turned off	Toggle EN, power cycle	No

(1) If tying the diagnostic $\overline{\text{FAULT}}$ pin high externally, the pullup must be strong enough to override the internal pulldown.

9.3.3.1 Open-Load Detection

The device detects an open-load condition when the voltage across the channel, $V_{(SUPPLY)} - V_{(IOUTx)}$, is less than the open-load detection voltage, $V_{(OLV)}$. When this condition is present for more than the open-load-detection deglitch time, 2 ms when PWM is 100% on or 7 continuous PWM duty cycles when in the PWM dimming mode, the device pulls $\overline{\text{FAULT}}$ low and turns off the faulted channel. With the $\overline{\text{FAULT}}$ pin tied high, all channels shut down. The channel recovers on removal of the open condition. Note that the device may also detect an open load if the sum of the forward voltages of the LEDs in a string is close to or greater than the supply voltage on the SUPPLY pin.

9.3.4 Thermal Foldback

The TPS92638-Q1 device integrates thermal shutdown protection to prevent the IC from overheating. In addition, to prevent LEDs from flickering due to rapid thermal changes, the device includes a programmable thermal current foldback feature to reduce power dissipation at high junction temperatures.

The TPS92638-Q1 device reduces the LED current as the silicon junction temperature of the TPS92638-Q1 device increases (see Figure 35). Mounting the TPS92638-Q1 device on the same thermal substrate as the LEDs allows use of this feature to limit the dissipation of the LEDs. As its junction temperature increases, the TPS92638-Q1 device reduces the regulated current level, thereby reducing the dissipated power in the TPS92638-Q1 and in the LEDs. The current reduction from the 100% level is typically 2% per degree Celsius until the point where the current drops to 50% of the full value, which occurs at $T_{(th)} + 20^\circ\text{C}$.

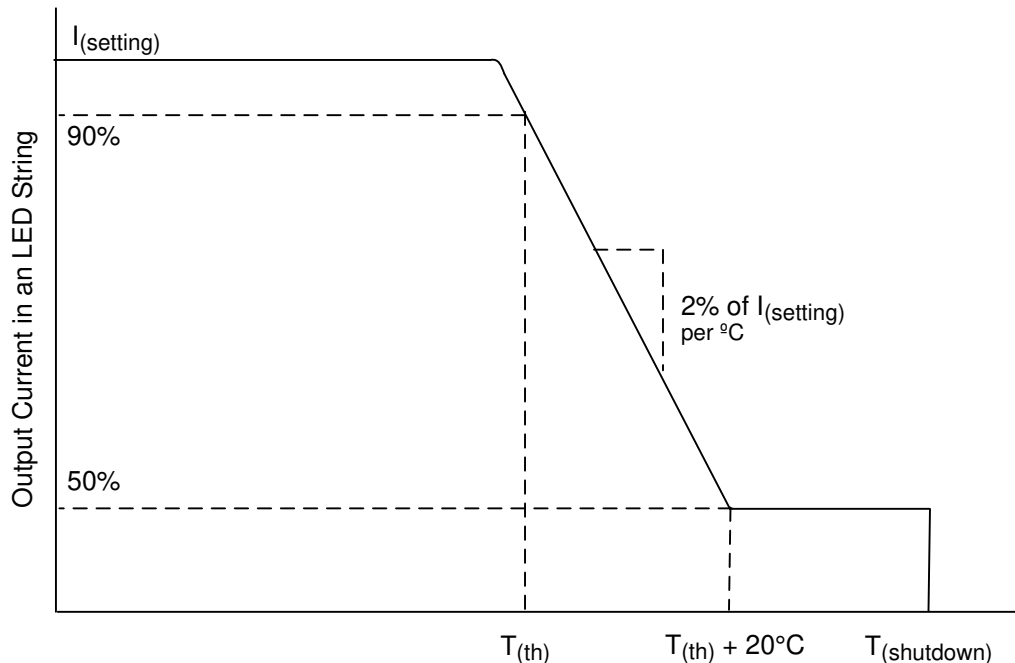

Figure 35. Thermal Foldback

Above this temperature, the device maintains the current at the 50% current level until the junction temperature reaches the overtemperature shutdown threshold, $T_{(shutdown)}$. Changing the voltage on the TEMP pin adjusts the temperature at which the current reduction begins. With TEMP left open, the definition of thermal monitor activation temperature is the temperature at which the current reduction begins, $T_{(th)}$. The specification of $T_{(th)}$ in the [Electrical Characteristics](#) table is at the 90% current level. $T_{(th)}$ increases as the voltage at the TEMP pin, $V_{(TEMP)}$, decreases. Equation 3 provides an approximate calculation of $T_{(th)}$.

$$T_{(th)} = -121.7 \text{ }^{\circ}C/V \times V_{(TEMP)} + 228.32^{\circ}C \tag{3}$$

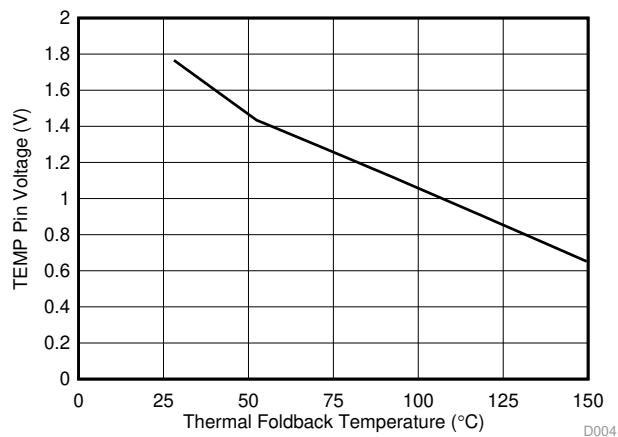

Figure 36. TEMP Pin Voltage vs Thermal Foldback Temperature

A resistor connected between TEMP and GND reduces $V_{(TEMP)}$ and increases $T_{(th)}$. A resistor connected between TEMP and a reference supply greater than 1 V increases $V_{(TEMP)}$ and reduces $T_{(th)}$.

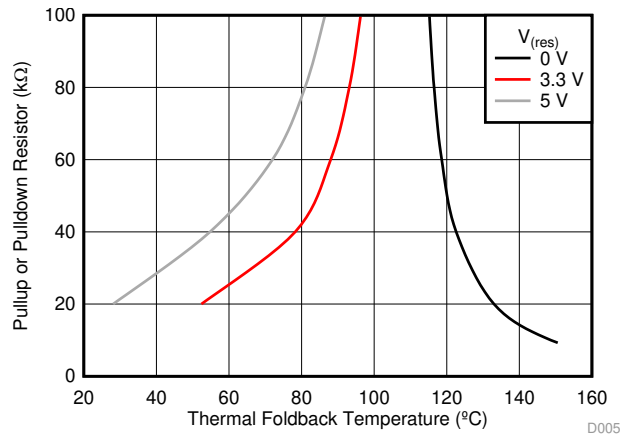

Figure 37. Pullup and Pulldown Resistors vs $T_{(th)}$

Figure 37 shows how the nominal value of the thermal monitor activation temperature varies with the voltage at TEMP and with a resistor $R_{(TEMP)}$, either connected to GND or pulled up to 3 V or to 5 V.

In extreme cases, if the junction temperature exceeds the overtemperature limit, $T_{(shutdown)}$, the device disables all regulators. Temperature monitoring continues, and the device re-activates the regulators, when the temperature drops below the specified hysteresis threshold.

Note that it is possible for the TPS92638-Q1 device to transition rapidly between thermal shutdown and normal operation. This can happen if the thermal mass attached to the exposed thermal pad is small and $T_{(th)}$ is too close to the shutdown temperature. The period of oscillation depends on $T_{(th)}$, the dissipated power, the thermal mass of any heatsink present, and the ambient temperature.

9.4 Device Functional Modes

The functional modes of the TPS92638-Q1 device are operational and non-operational. The device operates normally when $V_{(SUPPLY)}$ is at least 5 V and not greater than 40 V.

10 Application and Implementation

NOTE

Information in the following applications sections is not part of the TI component specification, and TI does not warrant its accuracy or completeness. TI's customers are responsible for determining suitability of components for their purposes. Customers should validate and test their design implementation to confirm system functionality.

10.1 Application Information

The following discussion includes several applications showing how to implement the TPS92638-Q1 device for automotive lighting such as stop lights and taillights. Some of the examples demonstrate implementation of the fault bus function or detail use of the device for higher-current applications.

10.2 Typical Applications

10.2.1 PWM Dimming by Bank

The TPS92638-Q1 device provides four PWM banks for output dimming. A TLC555-Q1 PWM generator can be used on the to avoid the use of an MCU.

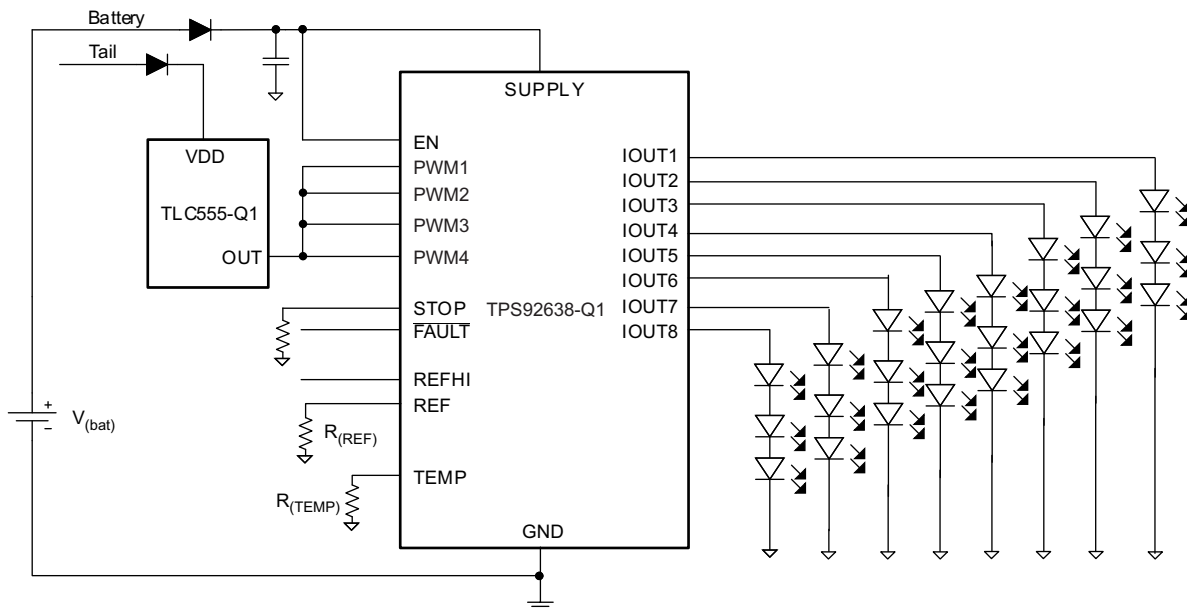

Figure 38. Schematic for PWM Dimming by Bank

10.2.1.1 Design Requirements

DESIGN PARAMETER	EXAMPLE VALUE
$I_{(TAIL)}$ ⁽¹⁾	20 mA
$I_{(STOP)}$ ⁽¹⁾	40 mA

(1) $I_{(TAIL)}$ = tail light current per channel; $I_{(STOP)}$ = stop light current per channel.

10.2.1.2 Detailed Design Procedure

The design uses the $R_{(REF)}$ reference resistor to set the maximum output current, and the TLC555-Q1 sets the PWM duty cycle to control the dimming ratio.

$$R_{(REF)} = V_{(REF)} \times \frac{G_{(I)}}{I_{(STOP)}} = 1.222 \times \frac{200}{0.04} = 6.11 \text{ k}\Omega$$

(4)

$$\text{Duty cycle} = \frac{I_{(\text{TAIL})}}{I_{(\text{STOP})}} = \frac{0.02}{0.04} = 0.5 = 50\%$$

(5)

10.2.1.3 Application Performance Plots

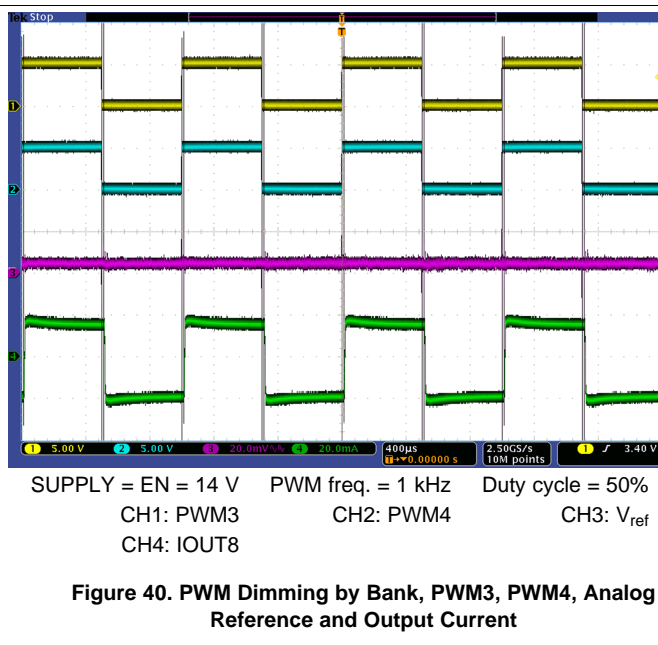
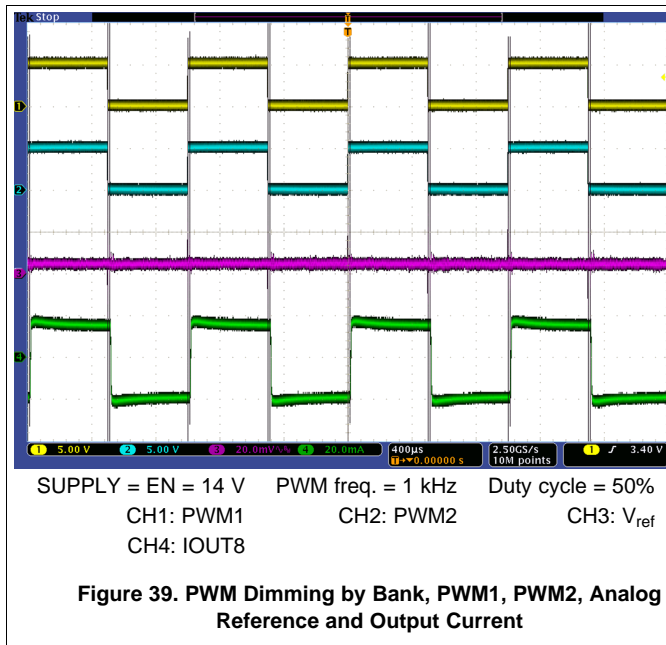

10.2.2 Two Brightness Levels for TAIL and STOP Lights

For a typical TAIL and STOP application, implementation using the TPS92638-Q1 device with an integrated STOP and TAIL function is easy. The following schematic depicts the application circuit. In a typical application, two independent sources, namely Tail and Stop, power the stop and tail lights. Using blocking diodes D0 and D1 with the TPS92638-Q1 device allows merging the STOP and TAIL functions, powered by a single supply. Blocking diode D2 protects the STOP pin during a reverse battery scenario. The STOP pin has an internal pulldown resistor to ensure a low state when STOP is not active.

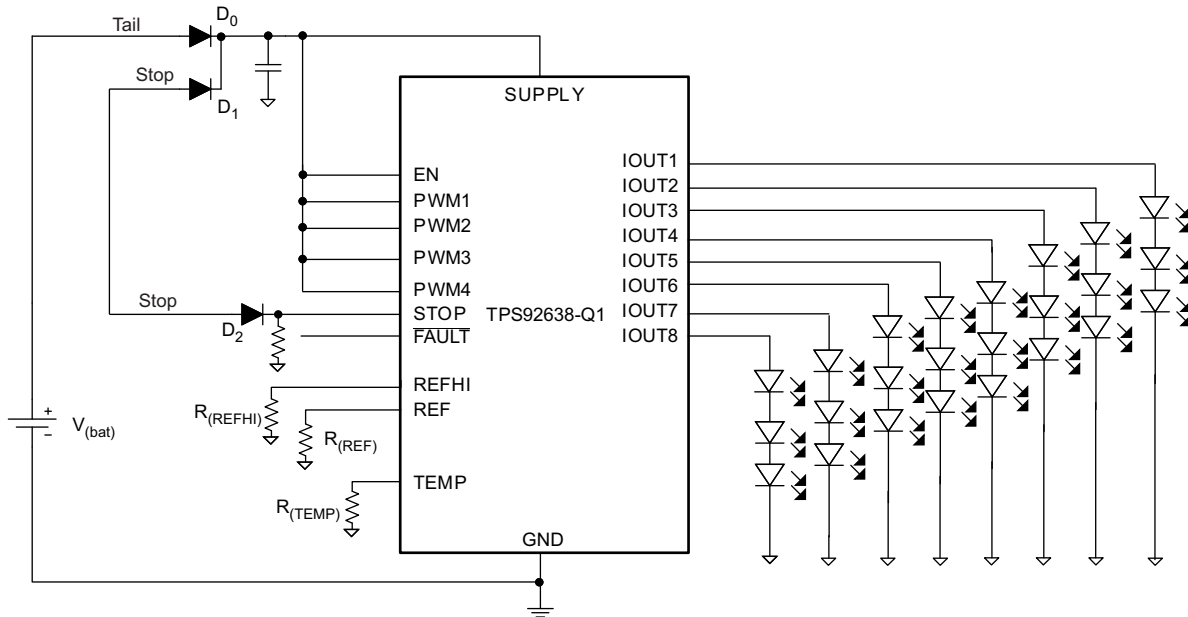

Figure 41. Schematic for Two Brightness Levels for TAIL and STOP Lights

10.2.2.1 Design Requirements

DESIGN PARAMETER	EXAMPLE VALUE
$I_{(TAIL)}^{(1)}$	10 mA
$I_{(STOP)}^{(1)}$	40 mA

(1) $I_{(TAIL)}$ = tail light current per channel; $I_{(STOP)}$ = stop light current per channel.

10.2.2.2 Detailed Design Procedure

Designing the application consists in calculating the values of resistors to be used for the desired output currents.

$$R_{(REF)} = V_{(REF)} \times \frac{G_{(I)}}{I_{(TAIL)}} = 1.222 \times \frac{200}{0.01} = 24.44 \text{ k}\Omega \quad (6)$$

$$R_{(REFHI)} = V_{(REFHI)} \times \frac{G_{(I)}}{I_{(STOP)} - I_{(TAIL)}} = 1.222 \times \frac{200}{0.04 - 0.01} = 8.146 \text{ k}\Omega \quad (7)$$

The recommended value for $R_{(STOP)}$ is 10 k Ω .

10.2.3 PWM Dimming by Modulated Supply

The TPS92638-Q1 device supports PWM dimming from the supply as depicted below. A high-side switch in the body control module (BCM) usually implements supply dimming. Due to the nature of the high-side switch, TPS92638-Q1 supply voltage is not strongly pulled down to ground, but depends on the decoupling capacitor and total current consumption. The TPS92638-Q1 device keeps the output current constant as long as supply voltage is adequate to overcome the LED forward voltage and dropout voltage.

When supply voltage drops too low to drive LEDs, the device shuts down the output channels on open-load detection. Therefore, TI recommends ensuring channel shutdown using the PWM or EN inputs. Thus a resistor string of R1 and R2 is recommended to ensure the lowest divided voltage is lower than PWM threshold.

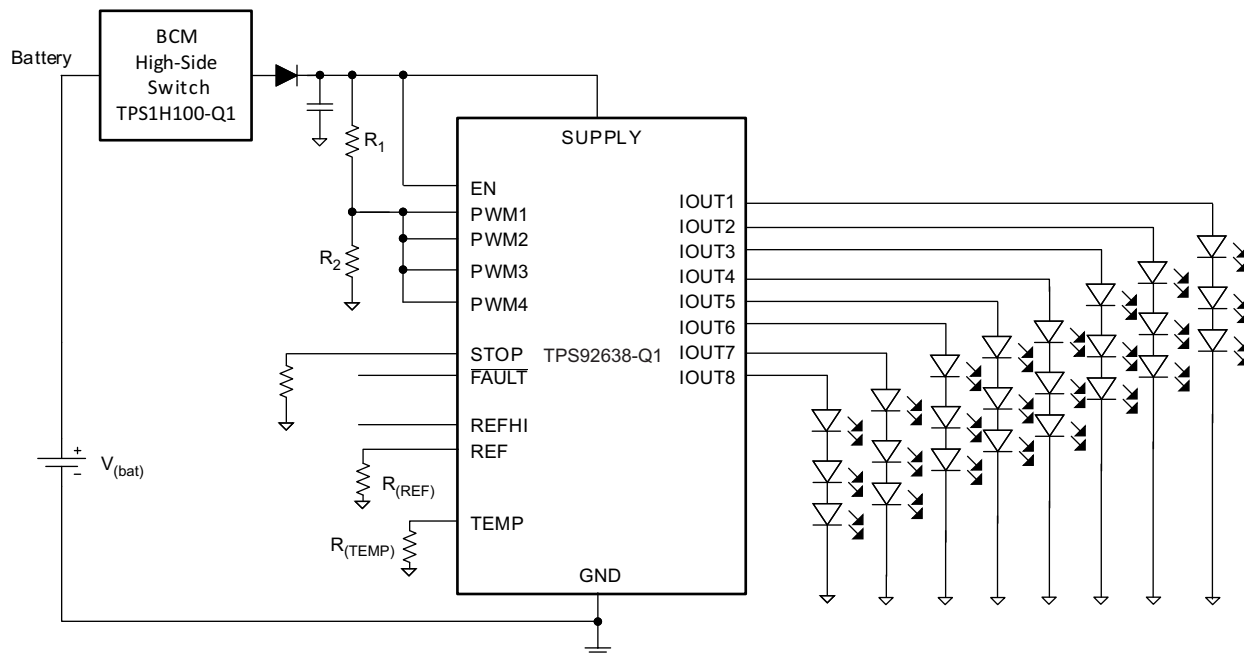

Figure 42. Schematic for PWM Dimming by Modulated Supply

10.2.3.1 Design Requirements

DESIGN PARAMETER	EXAMPLE VALUE
$I_{(TAIL)}^{(1)}$	30 mA
$I_{(STOP)}^{(1)}$	50 mA

(1) $I_{(TAIL)}$ = tail light current per channel; $I_{(STOP)}$ = stop light current per channel.

10.2.3.2 Design Procedure

The $R_{(REF)}$ reference resistor sets the current.

$$R_{(REF)} = V_{(REF)} \times \frac{G_{(I)}}{I_{(STOP)}} = 1.222 \times \frac{200}{0.05} = 4.888 \text{ k}\Omega \tag{8}$$

$$\text{Duty cycle} = \frac{I_{(TAIL)}}{I_{(STOP)}} = \frac{0.03}{0.05} = 0.6 = 60\% \tag{9}$$

$$V_{(SUPPLY) \text{ min}} \times \frac{R_2}{R_1 + R_2} < V_{(PWM_threshold)} \tag{10}$$

10.2.4 Driving LEDs From a Single Device With Channels in Parallel

The TPS92638-Q1 device the parallel driving of LED strings supports by combining multiple channels in parallel to achieve better thermal performance and higher current-driving capability.

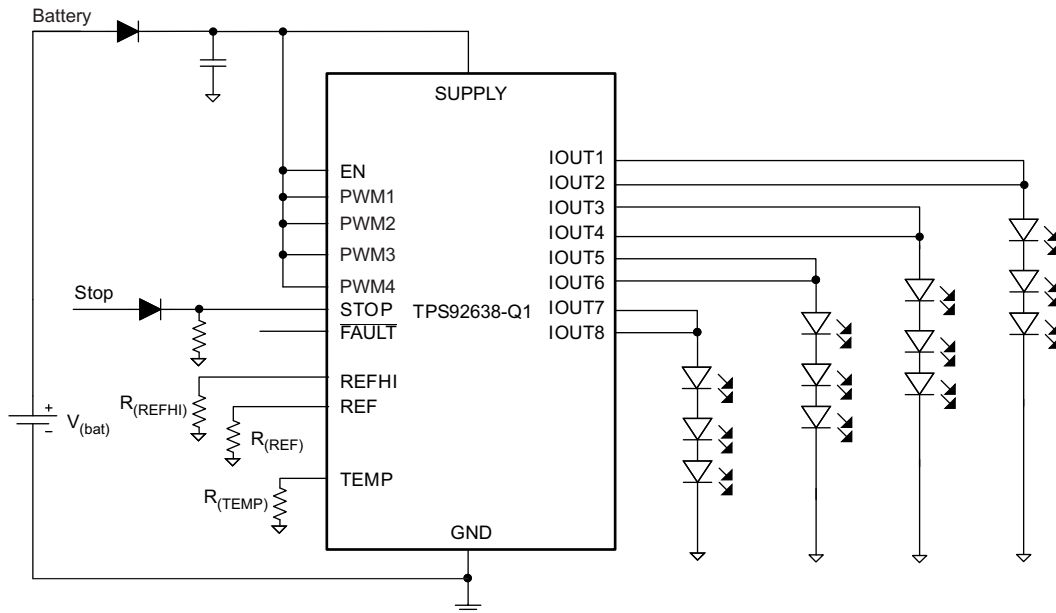

Figure 43. Schematic for Driving With a Single Device Using Parallel Channels

10.2.4.1 Design Requirements

DESIGN PARAMETER	EXAMPLE VALUE
$I_{(TAIL)}^{(1)}$	30 mA
$I_{(STOP)}^{(1)}$	100 mA

(1) $I_{(TAIL)}$ = tail light current per channel; $I_{(STOP)}$ = stop light current per channel.

10.2.4.2 Design Procedure

The $R_{(REF)}$ and $R_{(REFHI)}$ reference resistors set the current. $R_{(REF)}$ sets the tail current, and $R_{(REF)}$ and $R_{(REFHI)}$ set the stop current.

$$R_{(REF)} = V_{(REF)} \times \frac{G_{(I)}}{I_{(TAIL)} / N_{(channel)}} = 1.222 \times \frac{200}{0.03 / 2} = 16.29 \text{ k}\Omega \quad (11)$$

$$R_{(REFHI)} = V_{(REFHI)} \times \frac{G_{(I)}}{(I_{(STOP)} - I_{(TAIL)}) / N_{(channel)}} = 1.222 \times \frac{200}{(0.1 - 0.03) / 2} = 6.98 \text{ k}\Omega \quad (12)$$

10.2.5 Driving LEDs From Multiple Devices With Channels in Parallel

For design flexibility, there is also support for using multiple TPS92638-Q1 devices in parallel driving between different devices. The following diagram shows a combination that uses both devices and channels in parallel to drive high-current loads.

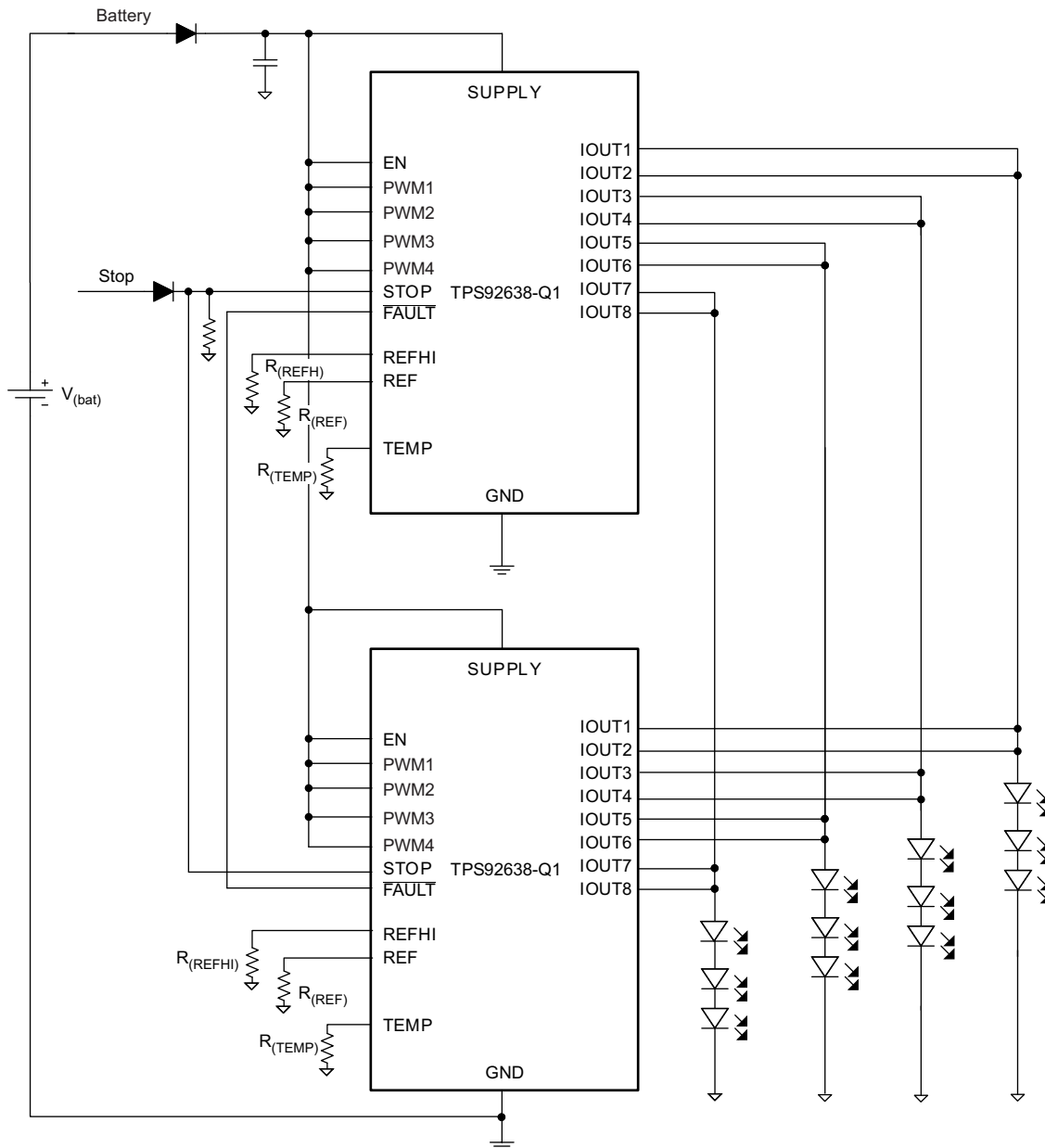

Figure 44. Schematic for Driving With Multiple Devices Using Parallel Channels

10.2.5.1 Design Requirements

DESIGN PARAMETER	EXAMPLE VALUE
$I_{(TAIL)}^{(1)}$	60 mA
$I_{(STOP)}^{(1)}$	200 mA

(1) $I_{(TAIL)}$ = tail light current per channel; $I_{(STOP)}$ = stop light current per channel.

10.2.5.2 Design Procedure

The $R_{(REFHI)}$ and $R_{(REF)}$ reference resistors set the current. $R_{(REF)}$ by itself sets the tail current. $R_{(REF)}$ and $R_{(REFHI)}$ together set the stop current. In different applications, reference resistors can be set to different values for different devices to achieve current flexibility. In this document, for simplicity, the application sets the same reference current in both devices.

$$R_{(REF)} = V_{(REF)} \times \frac{G_{(I)}}{I_{(TAIL)} / N_{(channel)}} = 1.222 \times \frac{200}{0.06 / 4} = 16.29 \text{ k}\Omega \quad (13)$$

$$R_{(REFHI)} = V_{(REFHI)} \times \frac{G_{(I)}}{(I_{(STOP)} - I_{(TAIL)}) / N_{(channel)}} = 1.222 \times \frac{200}{(0.2 - 0.06) / 4} = 6.98 \text{ k}\Omega \quad (14)$$

11 Power Supply Recommendations

The TPS92638-Q1 device is qualified for automotive applications. The normal power supply connection is therefore to an automobile electrical system that provides a voltage within the range specified in [Recommended Operating Conditions](#).

12 Layout

12.1 Layout Guidelines

In order to prevent thermal shutdown, T_J must be less than 150°C. If the input voltage is very high, the power dissipation might be large. Currently there is the TSSOP-EP package which has good thermal impedance, but at the same time, the PCB layout is also very important. Good PCB design can optimize heat transfer, which is absolutely essential for the long-term reliability of the device.

- Maximize the copper coverage on the PCB to increase the thermal conductivity of the board, because the major heat-flow path from the package to the ambient is through the copper on the PCB. Maximum copper is extremely important when there are not any heat sinks attached to the PCB on the other side of the package.
- Add as many thermal vias as possible directly under the package ground pad to optimize the thermal conductivity of the board.
- All thermal vias should be either plated shut or plugged and capped on both sides of the board to prevent solder voids. To ensure reliability and performance, the solder coverage should be at least 85%.

12.2 Layout Example

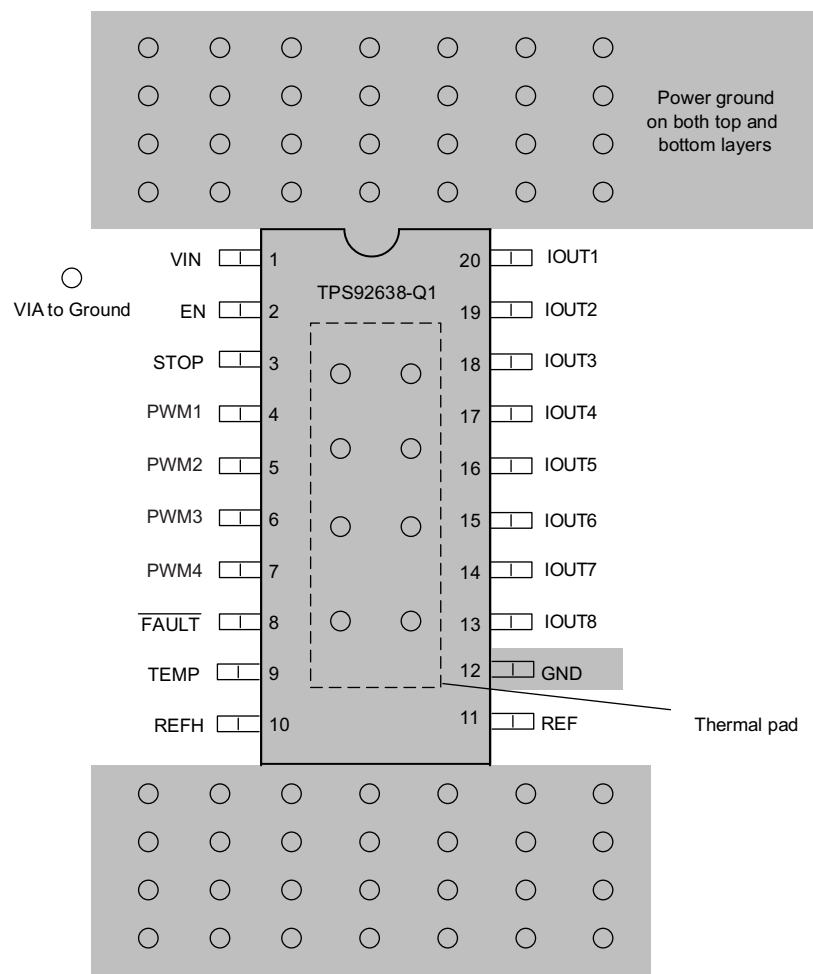

Figure 45. TPS92638-Q1 Layout Diagram

12.3 Thermal Information

This device operates a thermal shutdown (TSD) circuit as a protection from overheating. For continuous normal operation, the junction temperature should not exceed the thermal-shutdown trip point. If the junction temperature exceeds the thermal-shutdown trip point, the output turns off. When the junction temperature falls below the thermal-shutdown trip point minus hysteresis, the output turns on again.

Calculate the power dissipated by the device according to the following formula:

$$P_{(IC)} = V_{(SUPPLY)} \times I_{(SUPPLY)} - \sum_{k=1}^8 n_k \times V_{(LEDk)} \times I_{(LEDk)} - \frac{V_{(REF)}^2}{R_{(REF)}} - \frac{V_{(REFHI)}^2}{R_{(REFHI)}} \quad (15)$$

where:

n_k = Number of LEDs for x channel

$V_{(LEDk)}$ = Voltage drop across one LED for x channel

$V_{(REF)}$ = Reference voltage, typically 1.24 V

$I_{(LEDk)}$ = Average LED current for channel k

After determining the power dissipated by the device, calculate the junction temperature from the ambient temperature and the device thermal impedance.

$$T_J = T_A + R_{\theta JA} \times P_{(IC)} \quad (16)$$

where:

T_A = Ambient temperature

$R_{\theta JA}$ = Junction-to-ambient thermal impedance

$P_{(IC)}$ = Dissipated power

13 Device and Documentation Support

13.1 Trademarks

All trademarks are the property of their respective owners.

13.2 Electrostatic Discharge Caution



These devices have limited built-in ESD protection. The leads should be shorted together or the device placed in conductive foam during storage or handling to prevent electrostatic damage to the MOS gates.

13.3 Glossary

[SLYZ022](#) — *TI Glossary*.

This glossary lists and explains terms, acronyms, and definitions.

14 Mechanical, Packaging, and Orderable Information

The following pages include mechanical, packaging, and orderable information. This information is the most-current data available for the designated devices. This data is subject to change without notice and without revision of this document. For browser-based versions of this data sheet, see the left-hand navigation pane.

PACKAGING INFORMATION

Orderable Device	Status (1)	Package Type	Package Drawing	Pins	Package Qty	Eco Plan (2)	Lead finish/ Ball material (6)	MSL Peak Temp (3)	Op Temp (°C)	Device Marking (4/5)	Samples
TPS92638QPWRQ1	ACTIVE	HTSSOP	PWP	20	2000	RoHS & Green	NIPDAU	Level-3-260C-168 HR	-40 to 125	TPS92638	Samples

(1) The marketing status values are defined as follows:

ACTIVE: Product device recommended for new designs.

LIFEBUY: TI has announced that the device will be discontinued, and a lifetime-buy period is in effect.

NRND: Not recommended for new designs. Device is in production to support existing customers, but TI does not recommend using this part in a new design.

PREVIEW: Device has been announced but is not in production. Samples may or may not be available.

OBSOLETE: TI has discontinued the production of the device.

(2) **RoHS:** TI defines "RoHS" to mean semiconductor products that are compliant with the current EU RoHS requirements for all 10 RoHS substances, including the requirement that RoHS substance do not exceed 0.1% by weight in homogeneous materials. Where designed to be soldered at high temperatures, "RoHS" products are suitable for use in specified lead-free processes. TI may reference these types of products as "Pb-Free".

RoHS Exempt: TI defines "RoHS Exempt" to mean products that contain lead but are compliant with EU RoHS pursuant to a specific EU RoHS exemption.

Green: TI defines "Green" to mean the content of Chlorine (Cl) and Bromine (Br) based flame retardants meet JS709B low halogen requirements of <=1000ppm threshold. Antimony trioxide based flame retardants must also meet the <=1000ppm threshold requirement.

(3) MSL, Peak Temp. - The Moisture Sensitivity Level rating according to the JEDEC industry standard classifications, and peak solder temperature.

(4) There may be additional marking, which relates to the logo, the lot trace code information, or the environmental category on the device.

(5) Multiple Device Markings will be inside parentheses. Only one Device Marking contained in parentheses and separated by a "-" will appear on a device. If a line is indented then it is a continuation of the previous line and the two combined represent the entire Device Marking for that device.

(6) Lead finish/Ball material - Orderable Devices may have multiple material finish options. Finish options are separated by a vertical ruled line. Lead finish/Ball material values may wrap to two lines if the finish value exceeds the maximum column width.

Important Information and Disclaimer: The information provided on this page represents TI's knowledge and belief as of the date that it is provided. TI bases its knowledge and belief on information provided by third parties, and makes no representation or warranty as to the accuracy of such information. Efforts are underway to better integrate information from third parties. TI has taken and continues to take reasonable steps to provide representative and accurate information but may not have conducted destructive testing or chemical analysis on incoming materials and chemicals. TI and TI suppliers consider certain information to be proprietary, and thus CAS numbers and other limited information may not be available for release.

In no event shall TI's liability arising out of such information exceed the total purchase price of the TI part(s) at issue in this document sold by TI to Customer on an annual basis.

TAPE AND REEL INFORMATION

QUADRANT ASSIGNMENTS FOR PIN 1 ORIENTATION IN TAPE

*All dimensions are nominal

Device	Package Type	Package Drawing	Pins	SPQ	Reel Diameter (mm)	Reel Width W1 (mm)	A0 (mm)	B0 (mm)	K0 (mm)	P1 (mm)	W (mm)	Pin1 Quadrant
TPS92638QPWPRQ1	HTSSOP	PWP	20	2000	330.0	16.4	6.95	7.1	1.6	8.0	16.0	Q1

TAPE AND REEL BOX DIMENSIONS

*All dimensions are nominal

Device	Package Type	Package Drawing	Pins	SPQ	Length (mm)	Width (mm)	Height (mm)
TPS92638QPWPRQ1	HTSSOP	PWP	20	2000	350.0	350.0	43.0

MECHANICAL DATA

PWP (R-PDSO-G20)

PowerPAD™ PLASTIC SMALL OUTLINE



4073225-4/1 05/11

- NOTES:
- All linear dimensions are in millimeters.
 - This drawing is subject to change without notice.
 - Body dimensions do not include mold flash or protrusions. Mold flash and protrusion shall not exceed 0.15 per side.
 - This package is designed to be soldered to a thermal pad on the board. Refer to Technical Brief, PowerPad Thermally Enhanced Package, Texas Instruments Literature No. SLMA002 for information regarding recommended board layout. This document is available at www.ti.com <<http://www.ti.com>>.
 - See the additional figure in the Product Data Sheet for details regarding the exposed thermal pad features and dimensions.
 - Falls within JEDEC MO-153

PowerPAD is a trademark of Texas Instruments.

THERMAL PAD MECHANICAL DATA

PWP (R-PDSO-G20) PowerPAD™ SMALL PLASTIC OUTLINE

THERMAL INFORMATION

This PowerPAD™ package incorporates an exposed thermal pad that is designed to be attached to a printed circuit board (PCB). The thermal pad must be soldered directly to the PCB. After soldering, the PCB can be used as a heatsink. In addition, through the use of thermal vias, the thermal pad can be attached directly to the appropriate copper plane shown in the electrical schematic for the device, or alternatively, can be attached to a special heatsink structure designed into the PCB. This design optimizes the heat transfer from the integrated circuit (IC).

For additional information on the PowerPAD package and how to take advantage of its heat dissipating abilities, refer to Technical Brief, PowerPAD Thermally Enhanced Package, Texas Instruments Literature No. SLMA002 and Application Brief, PowerPAD Made Easy, Texas Instruments Literature No. SLMA004. Both documents are available at www.ti.com.

The exposed thermal pad dimensions for this package are shown in the following illustration.



Top View

Exposed Thermal Pad Dimensions

4206332-15/AO 01/16

NOTE: A. All linear dimensions are in millimeters

 Exposed tie strap features may not be present.

PowerPAD is a trademark of Texas Instruments

PWP (R-PDSO-G20)

PowerPAD™ PLASTIC SMALL OUTLINE



- NOTES:
- A. All linear dimensions are in millimeters.
 - B. This drawing is subject to change without notice.
 - C. Customers should place a note on the circuit board fabrication drawing not to alter the center solder mask defined pad.
 - D. This package is designed to be soldered to a thermal pad on the board. Refer to Technical Brief, PowerPad Thermally Enhanced Package, Texas Instruments Literature No. SLMA002, SLMA004, and also the Product Data Sheets for specific thermal information, via requirements, and recommended board layout. These documents are available at www.ti.com <<http://www.ti.com>>. Publication IPC-7351 is recommended for alternate designs.
 - E. Laser cutting apertures with trapezoidal walls and also rounding corners will offer better paste release. Customers should contact their board assembly site for stencil design recommendations. Example stencil design based on a 50% volumetric metal load solder paste. Refer to IPC-7525 for other stencil recommendations.
 - F. Customers should contact their board fabrication site for solder mask tolerances between and around signal pads.

IMPORTANT NOTICE AND DISCLAIMER

TI PROVIDES TECHNICAL AND RELIABILITY DATA (INCLUDING DATA SHEETS), DESIGN RESOURCES (INCLUDING REFERENCE DESIGNS), APPLICATION OR OTHER DESIGN ADVICE, WEB TOOLS, SAFETY INFORMATION, AND OTHER RESOURCES "AS IS" AND WITH ALL FAULTS, AND DISCLAIMS ALL WARRANTIES, EXPRESS AND IMPLIED, INCLUDING WITHOUT LIMITATION ANY IMPLIED WARRANTIES OF MERCHANTABILITY, FITNESS FOR A PARTICULAR PURPOSE OR NON-INFRINGEMENT OF THIRD PARTY INTELLECTUAL PROPERTY RIGHTS.

These resources are intended for skilled developers designing with TI products. You are solely responsible for (1) selecting the appropriate TI products for your application, (2) designing, validating and testing your application, and (3) ensuring your application meets applicable standards, and any other safety, security, regulatory or other requirements.

These resources are subject to change without notice. TI grants you permission to use these resources only for development of an application that uses the TI products described in the resource. Other reproduction and display of these resources is prohibited. No license is granted to any other TI intellectual property right or to any third party intellectual property right. TI disclaims responsibility for, and you will fully indemnify TI and its representatives against, any claims, damages, costs, losses, and liabilities arising out of your use of these resources.

TI's products are provided subject to [TI's Terms of Sale](#) or other applicable terms available either on ti.com or provided in conjunction with such TI products. TI's provision of these resources does not expand or otherwise alter TI's applicable warranties or warranty disclaimers for TI products.

TI objects to and rejects any additional or different terms you may have proposed.

Mailing Address: Texas Instruments, Post Office Box 655303, Dallas, Texas 75265
Copyright © 2022, Texas Instruments Incorporated